

– weishaupt –

product

Information on compact burners



The quiet heat source

Weishaupt WG5 gas burner (12.5 – 50 kW)

Hot for quality

Our motivation is technological progress, which has been driving us for more than 50 years to set new standards for the combustion industry.

Weishaupt's own Research and Development Centre is constantly working on both new developments and the optimisation of existing products.

It is our goal and our responsibility to go above and beyond current legislative requirements in developing combustion systems which produce fewer and fewer emissions, save more and more energy, and in so doing combine ecology and economy in a practical manner.

Therefore, not only do we invest in research and technology but we also only ever work on the best materials with modern tools and we carry out meticulous quality control checks.

It has been proven over a million times in the field that heating specialists and customers hold Weishaupt burners to be reliable, long lasting, environmentally friendly and technologically advanced. A fact also documented by numerous design and innovation prizes.

Over 600 burners are manufactured daily at our ultra-modern production facilities in Schwendi. Every single burner is subjected to a mechanical and electrical function test. The combination of technology with an effective quality control system safeguards Weishaupt's

renowned reputation for quality.

A new burner is always an investment in the future. Cost needs to be well balanced against use, but the final deciding factors for long term success are quality, technology and safety. Deciding for Weishaupt burners is therefore a safe investment in the future.





*Ultra-modern research and production methods
and rigorous quality control ensures the quality
for which Weishaupt is renowned*

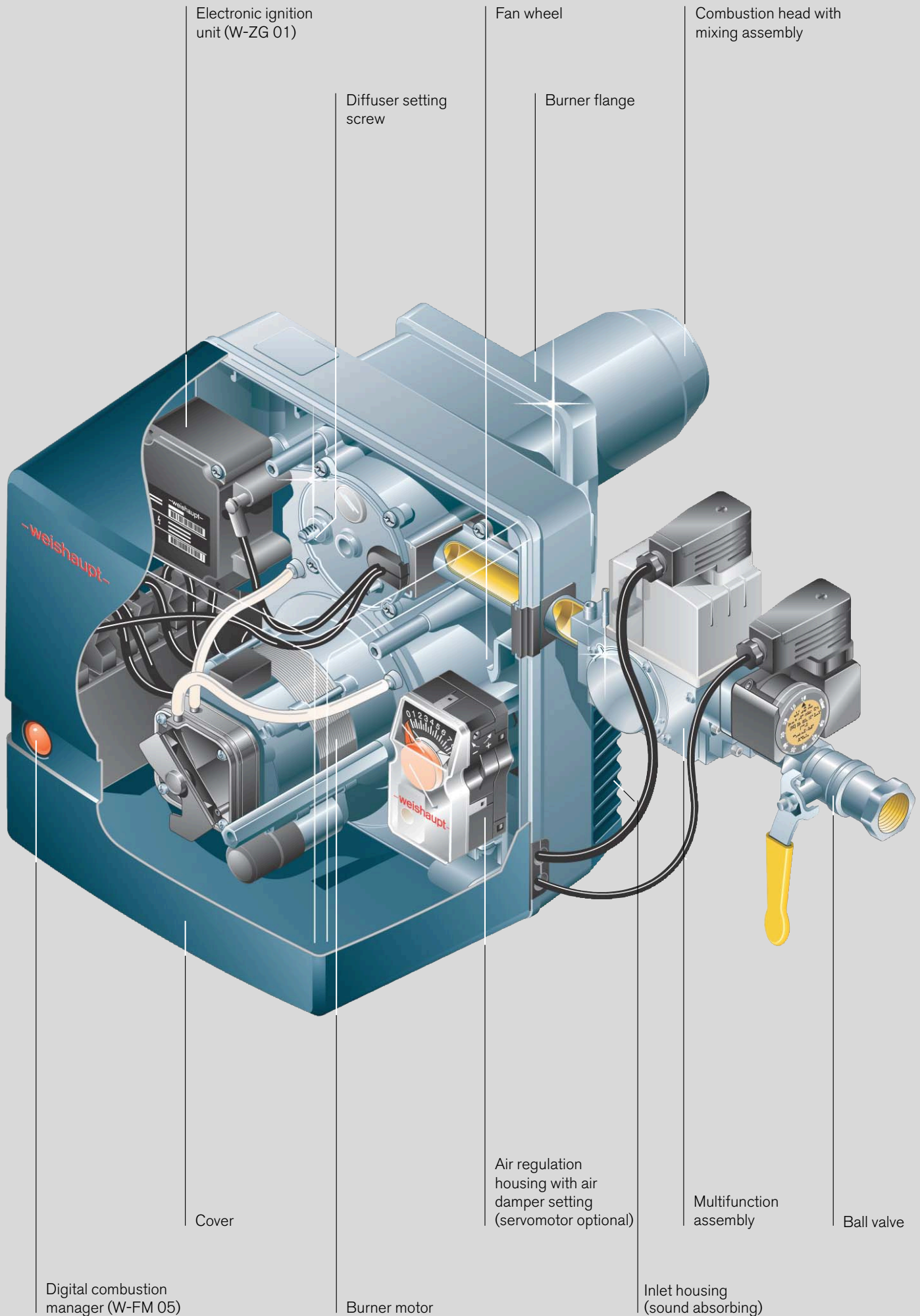

Electronic ignition unit (W-ZG 01)

Fan wheel

Combustion head with mixing assembly

Diffuser setting screw

Burner flange

-weishaupt-

Cover

Air regulation housing with air damper setting (servomotor optional)

Multifunction assembly

Ball valve

Digital combustion manager (W-FM 05)

Burner motor

Inlet housing (sound absorbing)

Well thought out technology – a Weishaupt burner operates simply

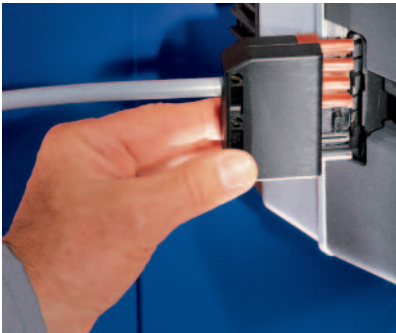

Non-interchangeable plugs for safe connections



Operating and fault conditions are indicated by coloured LEDs



Servicing is no problem thanks to the clearly laid out construction

A safe investment in the future

Reliable and economical: The millionfold success of the Weishaupt compact burners is the result of orienting without compromise towards quality and the customer. The technology has been constantly developed and improved over decades. The latest production methods and stringent quality checks of all products ensure Weishaupt's reputation for quality. You are making a safe investment in the future.

Proven quality

All burners are tested by an independent body and conform to the following standards and EU directives:

- EN 676
- Gas Appliance Directive 90/396/EEC
- Machinery Directive 98/37/EC
- Electromagnetic Compatibility Directive 89/336/EEC
- Low Voltage Directive 73/23/EEC
- Boiler Efficiency Directive 92/42/EEC
- Pressure Equipment Directive 97/23/EC

Environmentally friendly

All WG gas burners are Low NO_x executon as standard. A specially designed mixing head produces an intensive internal flue gas recirculation, resulting in exemplary emissions levels.

Digital combustion management for safety and ease of use

All Weishaupt W series burners are fitted with digital combustion managers as standard, whose microprocessors control and monitor all burner functions. The result: Weishaupt burners are easy to use, precise and safe, with the pleasing side effect of a particularly good price/capacity relationship. The digital combustion managers also offer the possibility of communicating with other systems via an integrated eBUS port. This enables the heating engineer to monitor the operation of the burner and remotely diagnose any errors.

Outstanding service

Weishaupt has an extensive sales and service network worldwide. Customer service is available around the clock. Optimal in-house training at Weishaupt ensures our service engineers are of the highest calibre.

Trustworthy technology

Even the visual impression after removing the burner cover is convincing. All components are clearly arranged, the electrical connections are obvious and non-interchangeable. The technology makes a good impression because it is typical Weishaupt.

Sound attenuated air inlet

The transverse fan is sound attenuated on the suction side. These burners therefore operate particularly quietly.

Electronically controlled air damper

The electronically controlled air damper closes at burner shutdown to hinder the cooling-down of the combustion chamber.

Sevicing position

A special bracket enables the burner to be put into a servicing position, which enabling easy access to the burner and mixing assembly.

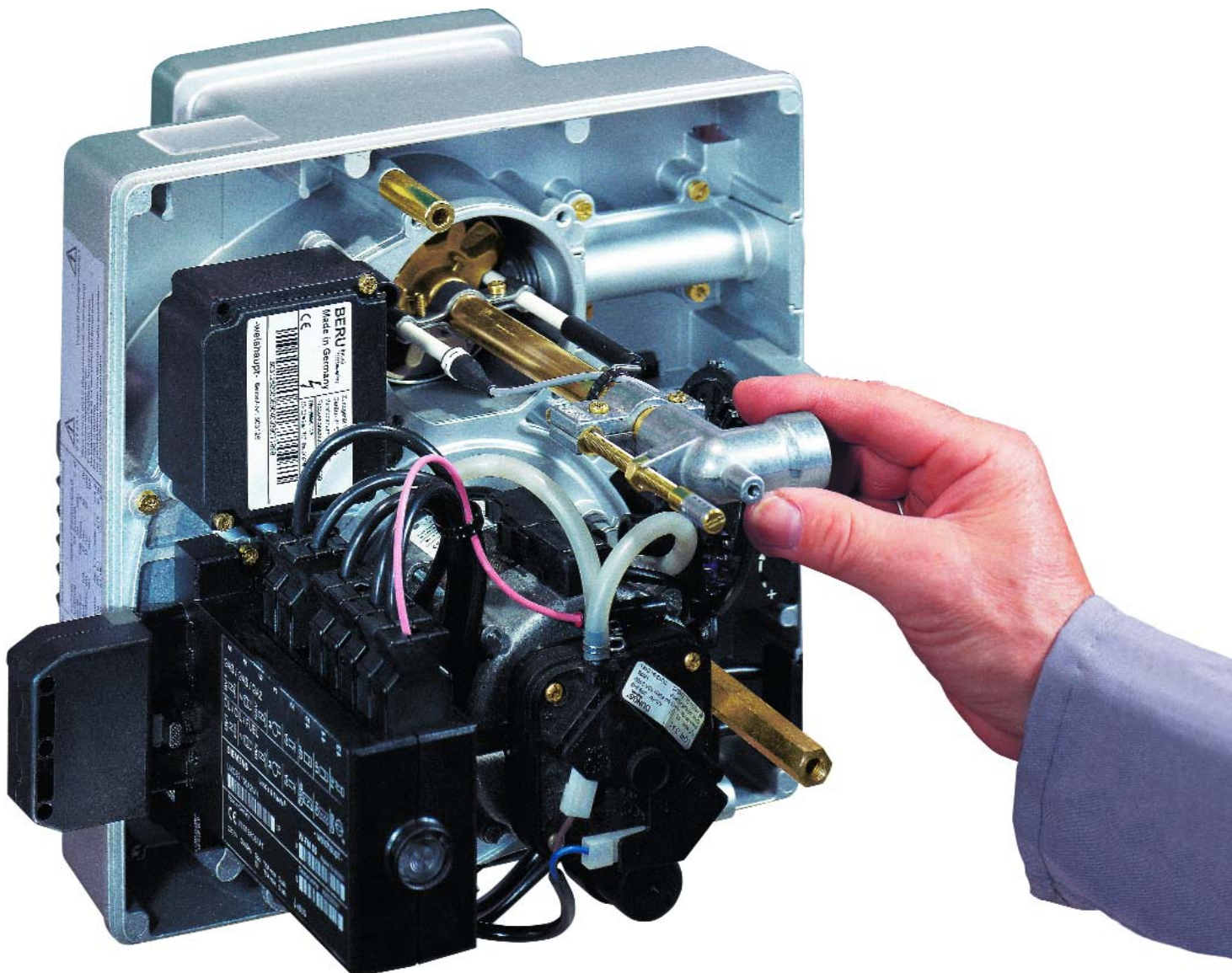

Easy access to the mixing assembly

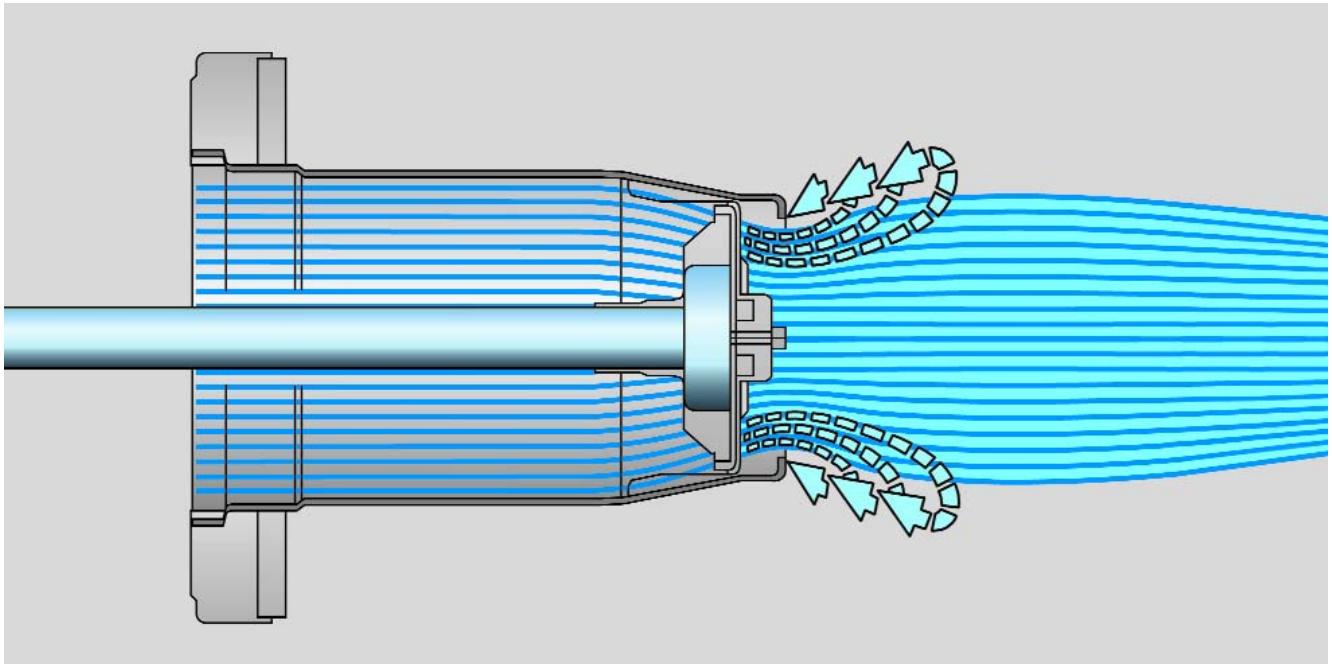

Flue gas recirculation reduces emissions

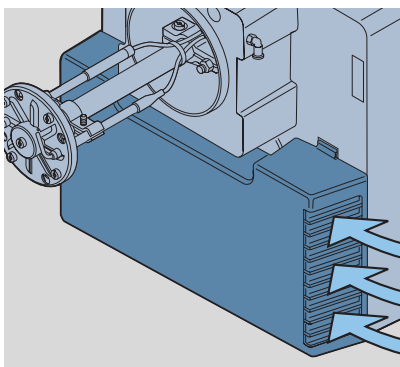

Sound attenuated air inlet

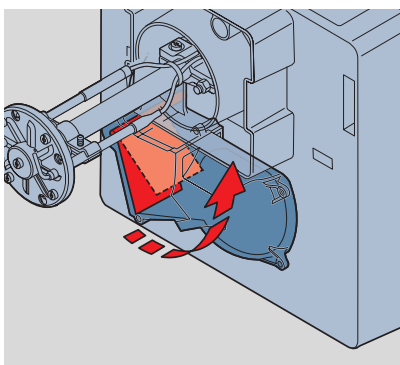

Electronically controlled air damper

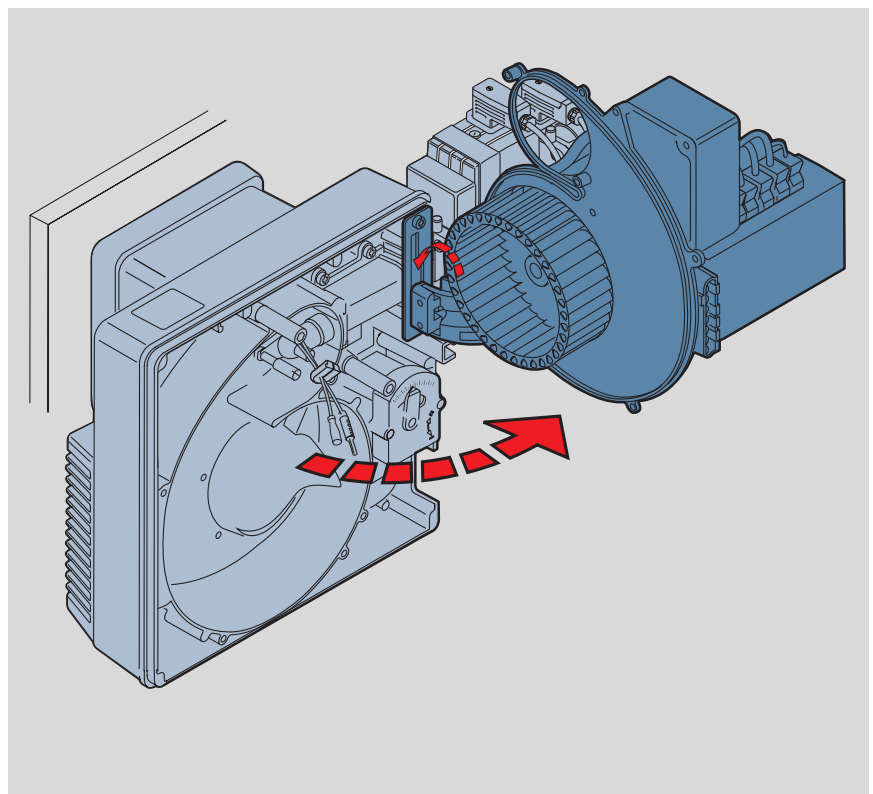

Cover with internal components in the servicing position: Easy fan access

Technical data

Type	Capacity range	Mode of operation	Fuel	Power Consumpt.	Weight	Order No.
Gas burner						
WG 5 N/1-A LN	12.5 – 50 kW	Single stage	E, LL	0.040 kW	12.0 kg	232 050 11
WG 5 N/1-A LN	12.5 – 50 kW	Single stage with servomotor	E, LL	0.040 kW	12.0 kg	232 050 10
WG 5 F/1-A LN	12.5 – 50 kW	Single stage	B/P	0.040 kW	12.0 kg	233 050 11

(See price list for special equipment)

Capacity graph WG 5.../1-A, single stage

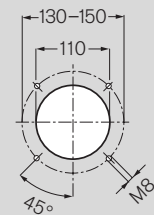
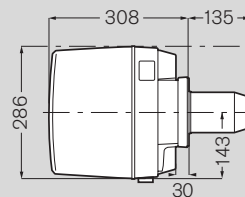
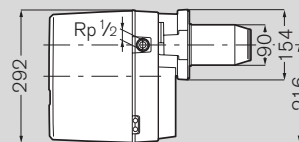
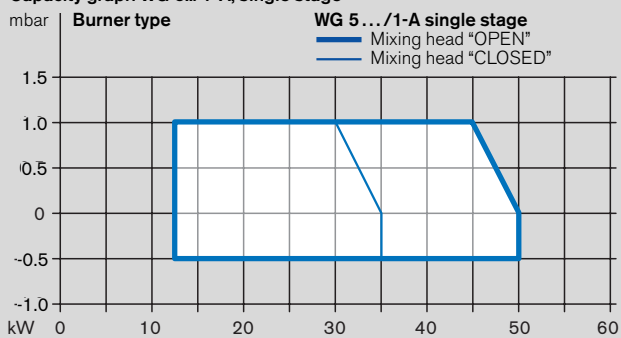

Dimensions in mm