

– weishaupt –

# product

Information on WK-series burners



## WK-series industrial burners

**WK 40 to WK 80 burners • 300 kW to 28,000 kW**

# The powerful industrial burner with a modular construction

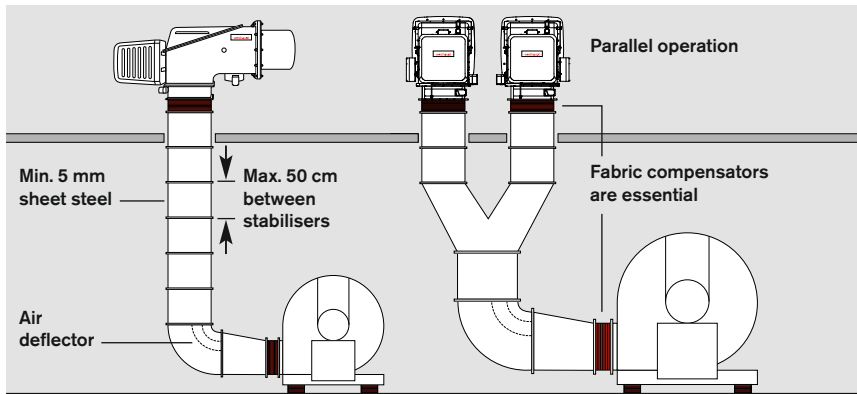

Combustion-air ducting

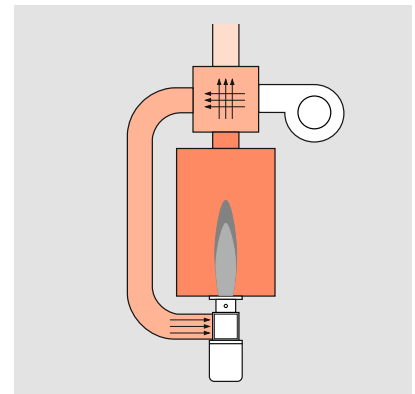

Combustion air temperatures up to 250 °C

**Weishaupt WK-series burners have been designed especially for industrial use. The modular design of the burners, coupled with their large capacity range, makes them ideally suited to a broad spectrum of special applications.**

## Modular principle

Weishaupt WK-series industrial burners are of modular design. That means the fan, pump station, and preheater station are all selected independently of the burner. This concept offers a high degree of flexibility in matching to the most diverse applications.

## Digital combustion management

Digital combustion management ensures the simple and safe operation of combustion plant. Emissions are minimised and economy is maximised.

## Insulated burner housing

The burner housing is fitted with internal insulation as standard. This significantly reduces the surface temperature of the housing during operation with preheated combustion air. The insulation also provides effective noise reduction.

## Heat recovery using preheated combustion air

Many industrial processes create high flue-gas temperatures due to the high temperature of the medium used. A heat exchanger in the flue can be used to reclaim a large amount of energy

from these hot flue gases, increasing efficiency by up to 10 %. Weishaupt WK-series industrial burners can be operated with preheated combustion-air temperatures of up to 250 °C.

## Nozzle-head shut-off device

At burner shutdown, or when changing over to gas operation, a safety shut-off device located in the oil atomising system shuts off the oil flow directly in the nozzle orifice, preventing the escape of any oil.

## Modulating operation

Within its operating range, the burner's output is matched to the current heat demand.

## Reduced capacity at start-up

A gas pilot line enables all gas-firing burners and WK(G)MS 80 burners up to 17.5 MW to start operation at a reduced ignition load. This means that only a small quantity of gas flows into the combustion chamber. After the ignition phase, the burner drives to partial load.

## Controlled shutdown from partial load

Controlled shutdown of the burner always takes place from the partial-load position, thus preventing impact on the gas main.

## Fuels

- Fuel oil EL (< 6 mm<sup>2</sup>/s at 20 °C) in accordance with DIN 51 603-1
- Fuel oil S (< 60 mm<sup>2</sup>/s at 100 °C) (< 700 mm<sup>2</sup>/s at 50 °C) in accordance with DIN 51 603-3/-5
- Natural gas E
- Natural gas LL
- LPG B/P

## Permissible ambient conditions

- Ambient temperature during operation: -15 to +40 °C
- Humidity: max. 80 % relative humidity, no condensation
- Standard burner protection: IP 54



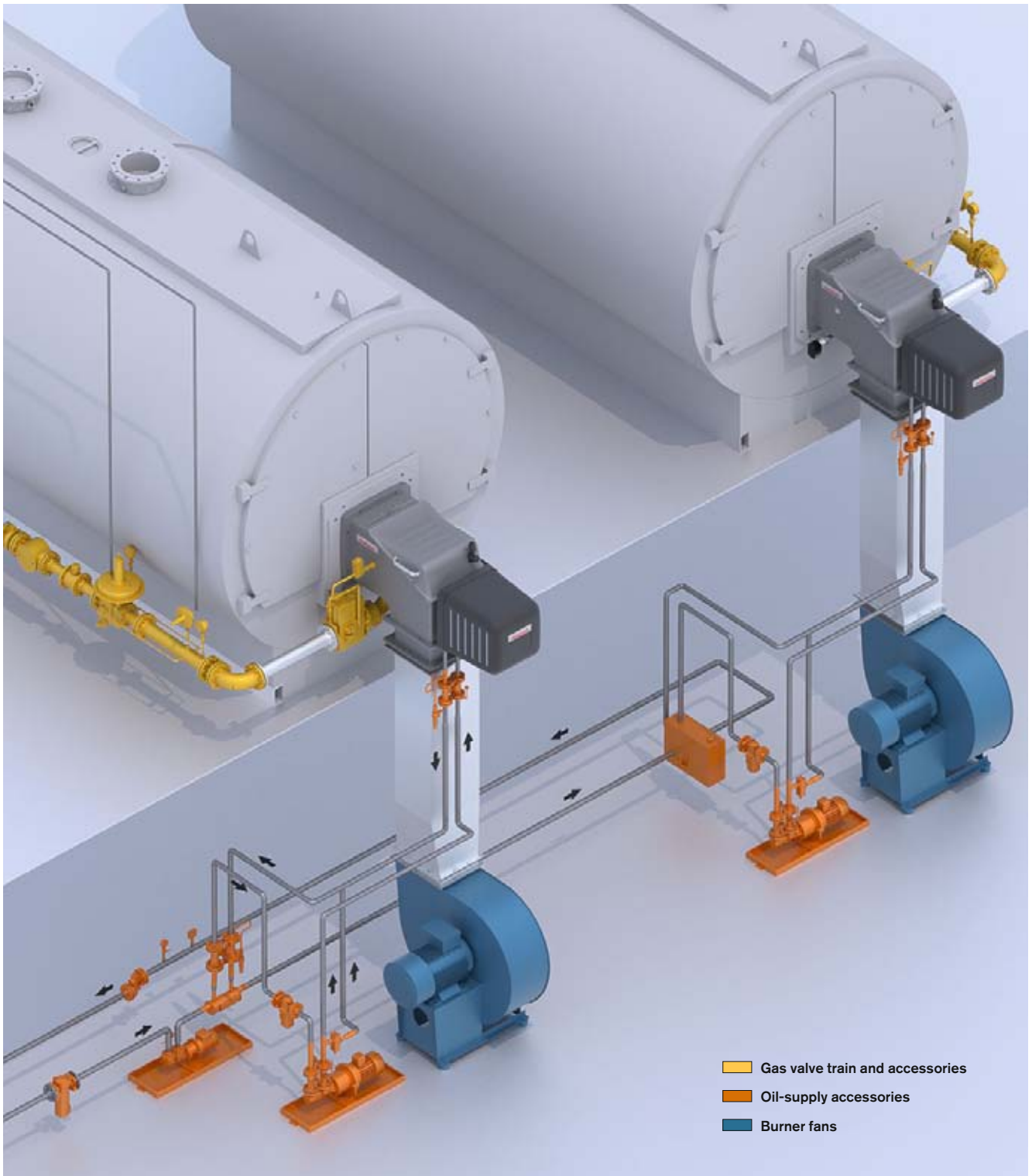

## Standards conformity

- EN 267 and EN 676
- Pressure Equipment Directive, 97/23/EC
- Gas Appliance Directive, 2009/142/EC
- Machinery Directive, 2006/42/EC
- Electromagnetic Compatibility Directive, 2004/108/EC
- Low Voltage Directive, 2006/95/EC
- The burners are marked with a
  - CE mark
  - CE Product ID No.
  - Type-test No.



*A one-stop solution for reliability*

# The right mixing assembly for every application



	Fuels				Flame geometry	NO <sub>x</sub> Class per EN 267 / 676 <sup>1)</sup>	
	Natural gas	LPG	Light oil	Heavy oil		Gas	Oil (light oil)
<p><b>ZM / NR</b> Mixing assembly for gas, oil, and dual-fuel burners</p> <p>ZM: For plant with no particular NO<sub>x</sub> requirements</p> <p>NR: Gas-side NO<sub>x</sub> reduction compared to ZM version</p>	●	●	●	●		1	1
<p><b>1LN</b> Low-NO<sub>x</sub> mixing assembly for gas and dual-fuel burners</p> <p>For plant with gas and oil-side NO<sub>x</sub> requirements</p>	●	●	●			3	2
<p><b>LN</b> Low-NO<sub>x</sub> mixing assembly for gas burners</p> <p>Further reduction in NO<sub>x</sub> emissions compared to 1LN-version burners</p>	●					3	—
<p><b>3LN</b> Low-NO<sub>x</sub> mixing assembly for gas, oil, and dual-fuel burners</p> <p>For plant with extremely low NO<sub>x</sub> limits. Lowest NO<sub>x</sub> emissions in comparison with all other versions</p>	●	● <sup>2)</sup>	●			3	3

NO<sub>x</sub> emissions
  Undergoing type approval
  No type approval

<sup>1)</sup> With combustion air temperatures < 40 °C

<sup>2)</sup> Except WK 80

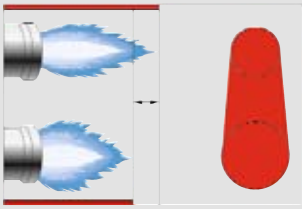
<sup>3)</sup> Minimum requirements for the combustion-chamber geometry must be approved by the manufacturer

	Fuels					Flame geometry		NO <sub>x</sub> Class per EN 267 / 676 <sup>1)</sup>	
	Natural gas	LPG	Light oil	Heavy oil		Length	Width/diameter	Gas	Oil (light oil)
<p><b>1SF</b> Mixing assembly for gas, oil, and dual-fuel burners</p> <p>Mixing assembly for extremely short combustion chambers and for elongated combustion chambers (D-type) in water-tube boilers with low cross-sectional loads (&lt; 12 MW/m<sup>2</sup>).</p> <p>The flame geometry can be optimised using fixtures and by adjusting burner settings. <sup>3)</sup></p>	●	●	●	●					

■ NO<sub>x</sub> emissions     
 ● Undergoing type approval     
 ● No type approval

## EN emission classes <sup>1)</sup>

Oil-burner emission classes (light oil)	NO <sub>x</sub> emissions in mg/kWh (EN 267)
1	≤ 250
2	≤ 185
3	≤ 120
Gas-burner emission classes (natural gas E / LL)	NO <sub>x</sub> emissions in mg/kWh (EN 676)
1	≤ 170
2	≤ 120
3	≤ 80
Gas-burner emission classes (LPG B / P)	NO <sub>x</sub> emissions in mg/kWh (EN 676)
1	≤ 230
2	≤ 180
3	≤ 140

<sup>1)</sup> For combustion air temperatures < 40 °C

<sup>2)</sup> Except WK 80

<sup>3)</sup> Minimum requirements for the combustion-chamber geometry must be approved by the manufacturer

# Overview of capacities Gas burners

## Version ZM

### WKG natural-gas and LPG burners

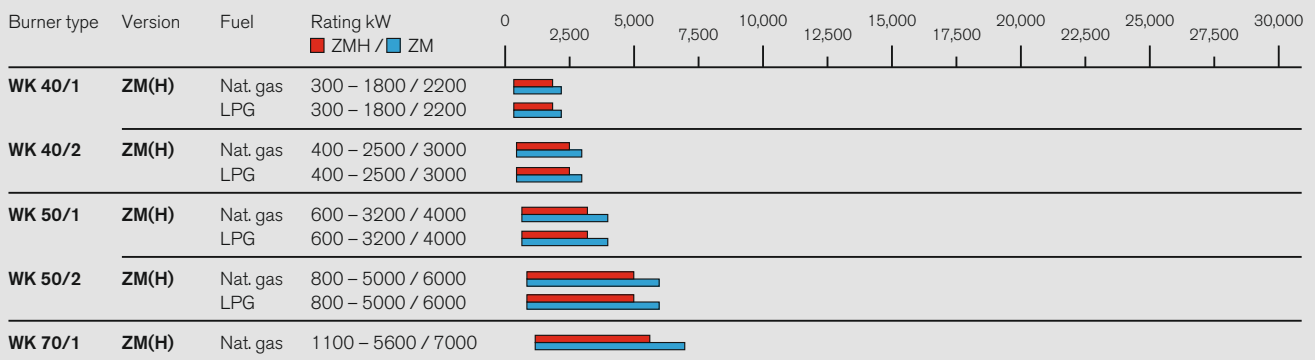

## Version NR

### WKG natural-gas and LPG burners

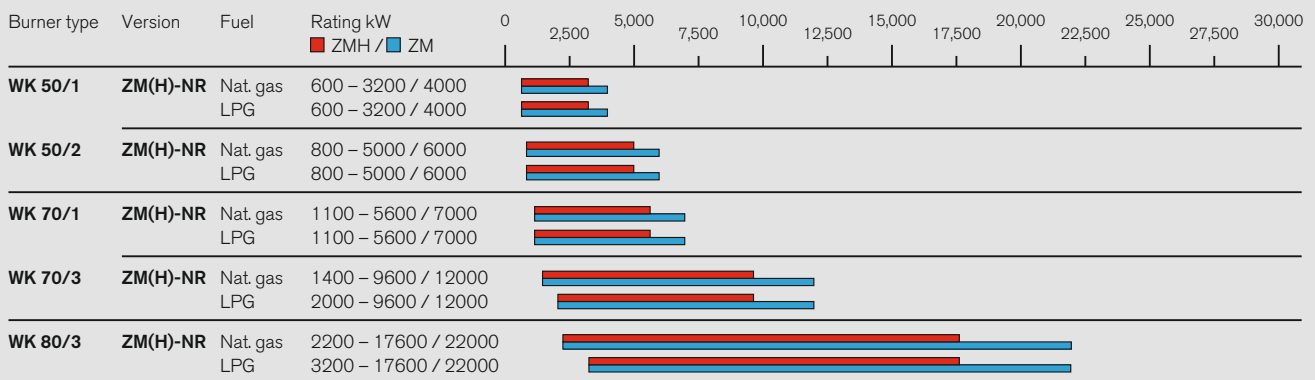

## Version 1LN

### WKG natural-gas and LPG burners

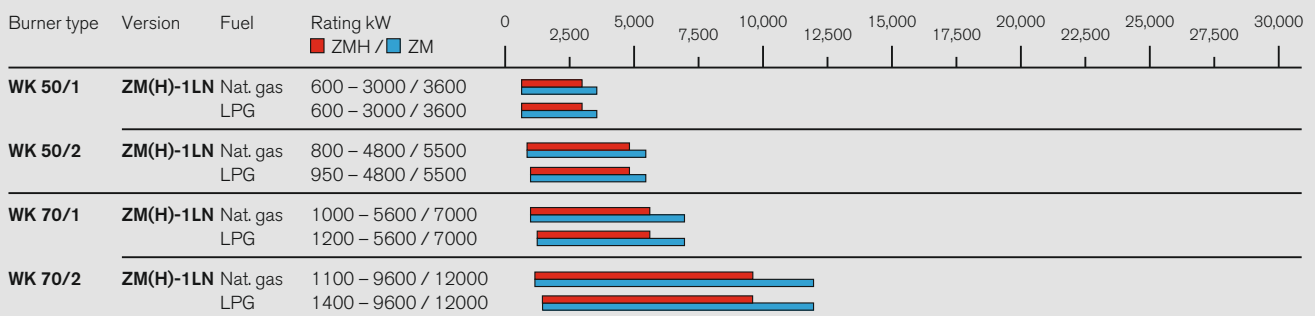

- Version ZM: Combustion air temperatures up to 20 °C
- Version ZMH: Combustion air temperatures up to 100 °C
- Version ZMH: Combustion air temperatures up to 250 °C

See the planning and installation handbook for fan selection and arrangement, gas valve trains, special equipment, technical data, and dimensions.

## Version LN

### WKG natural-gas burners

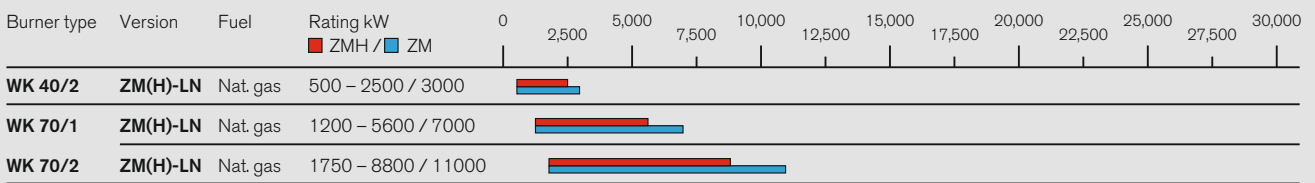

## Version 3LN multiflam®

### WKG natural-gas burners

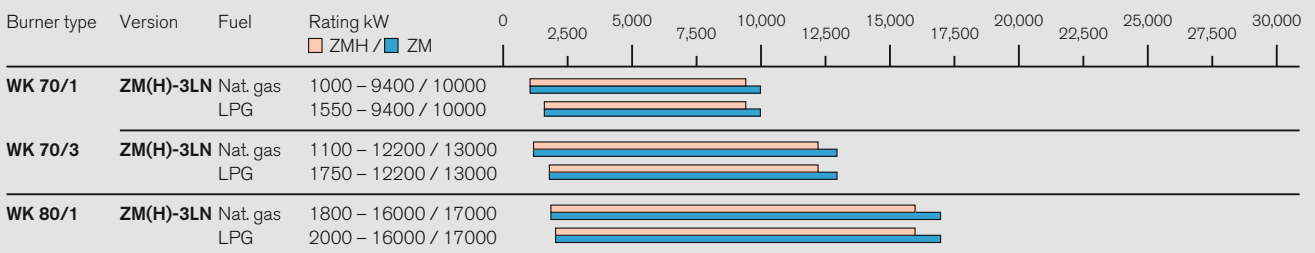

## Version 1SF

### WKG natural-gas and LPG burners

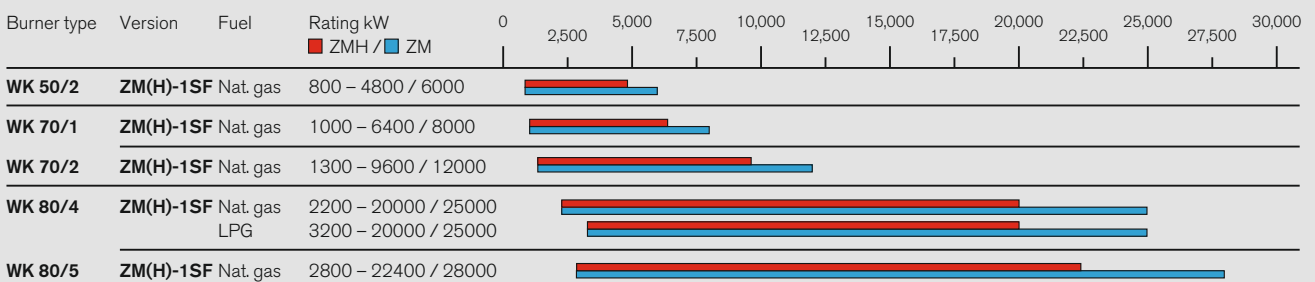

- Version ZM: Combustion air temperatures up to 20 °C
- Version ZMH: Combustion air temperatures up to 100 °C
- Version ZMH: Combustion air temperatures up to 250 °C

See the planning and installation handbook for fan selection and arrangement, gas valve trains, special equipment, technical data, and dimensions.

# Overview of capacities Oil burners

## Version ZM

### WKL and WKMS light and heavy-oil burners

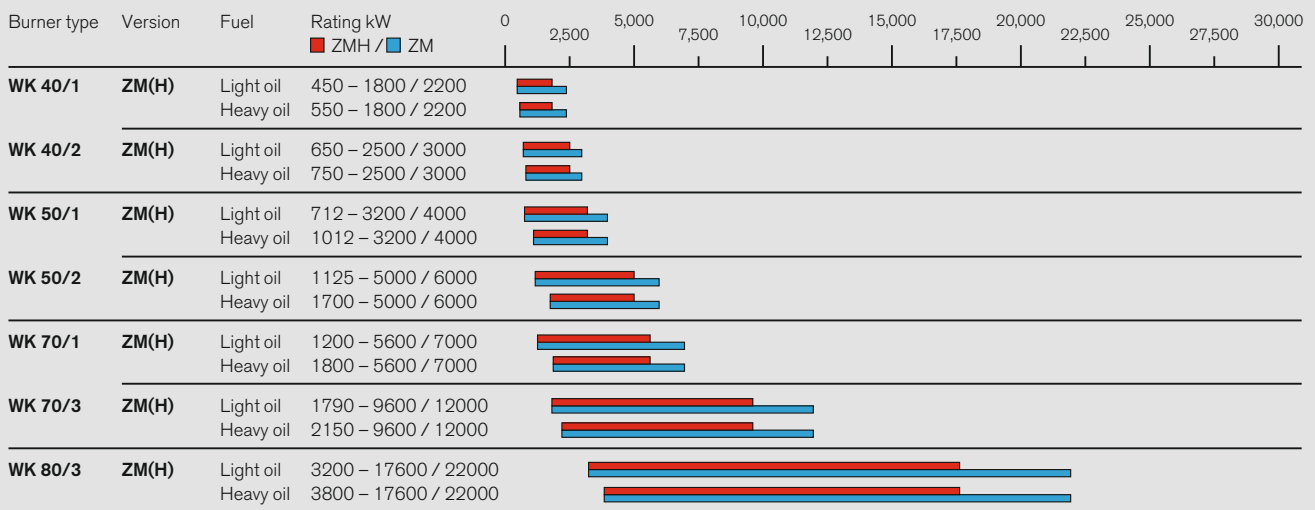

## Version 3LN multiflam®

### WKGL light-oil burners \*

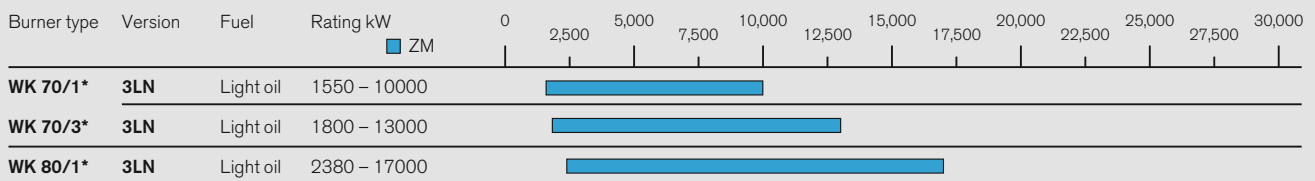

\* 3LN-version WK 70 and WK 80 burners are not available as single-fuel oil burners. However, the WKGL dual-fuel burners are available in a special execution "without gas-side components". Refer to the price list for the appropriate price reduction.

## Version 1SF

### WKL and WKMS light and heavy-oil burners

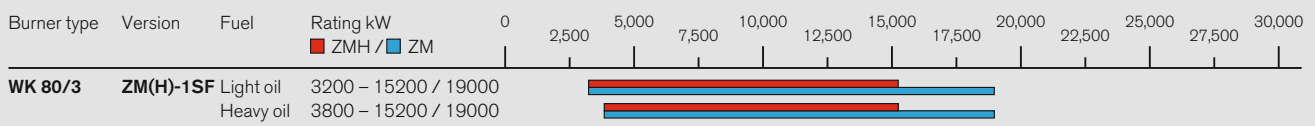

- Version ZM: Combustion air temperatures up to 20 °C
- Version ZMH: Combustion air temperatures up to 100 °C
- Version ZMH: Combustion air temperatures up to 250 °C

See the planning and installation handbook for fan selection and arrangement, gas valve trains, special equipment, technical data, and dimensions.

# Overview of capacities Dual-fuel burners

## Version ZM

### WKGL and WKGMS dual-fuel burners

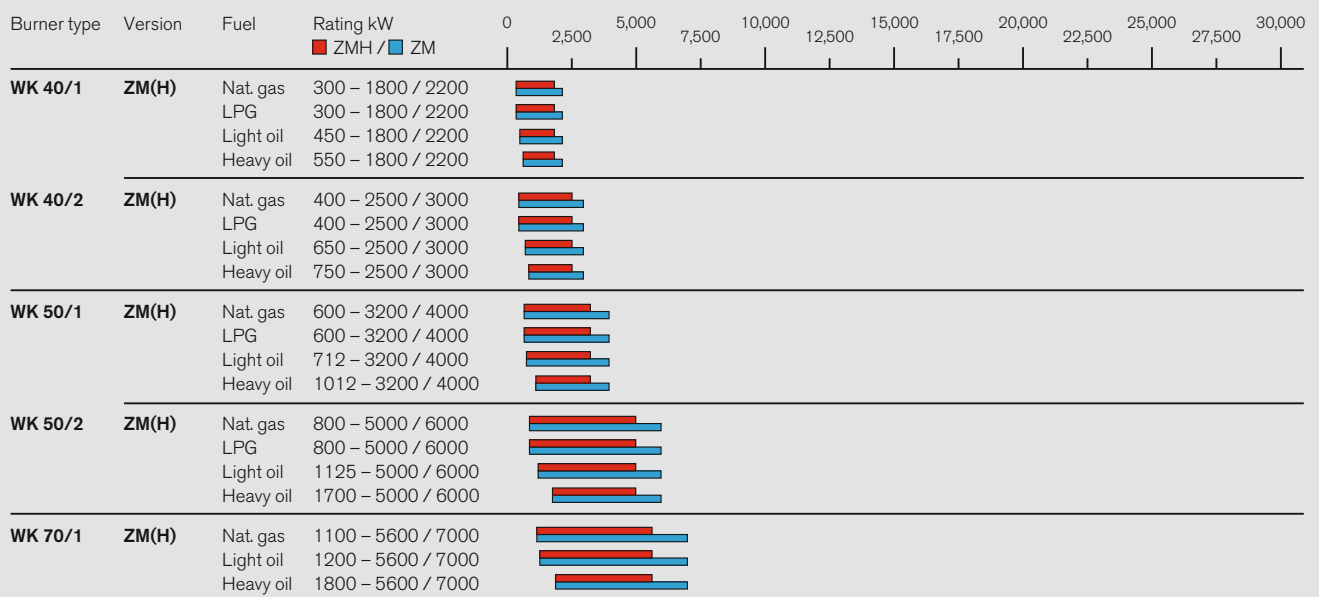

- Version ZM: Combustion air temperatures up to 20 °C
- Version ZMH: Combustion air temperatures up to 100 °C
- Version ZMH: Combustion air temperatures up to 250 °C

See the planning and installation handbook for fan selection and arrangement, gas valve trains, special equipment, technical data, and dimensions.

# Overview of capacities

## Dual-fuel burners

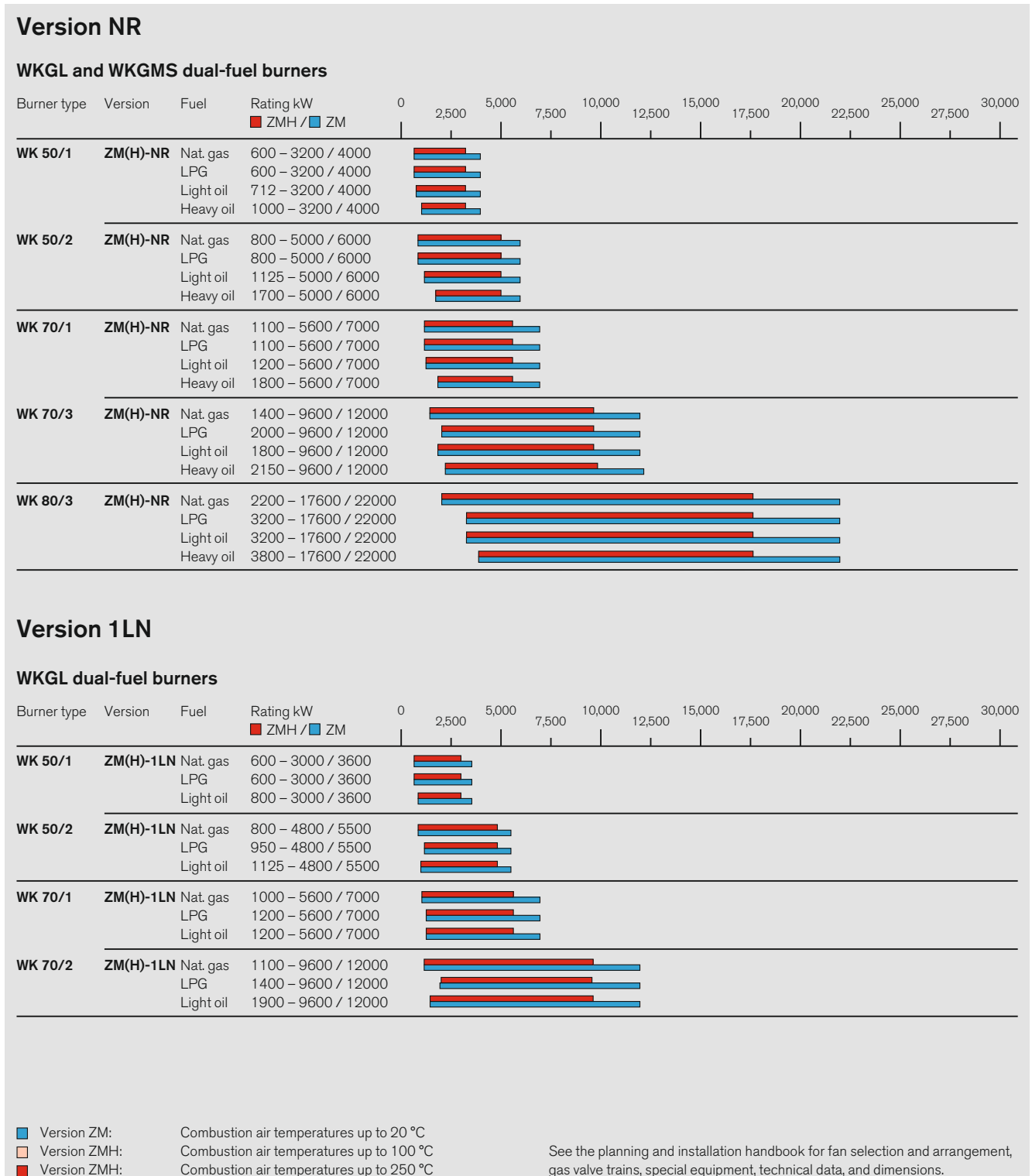

## Version 3LN multiflam®

### WKGL dual-fuel burners

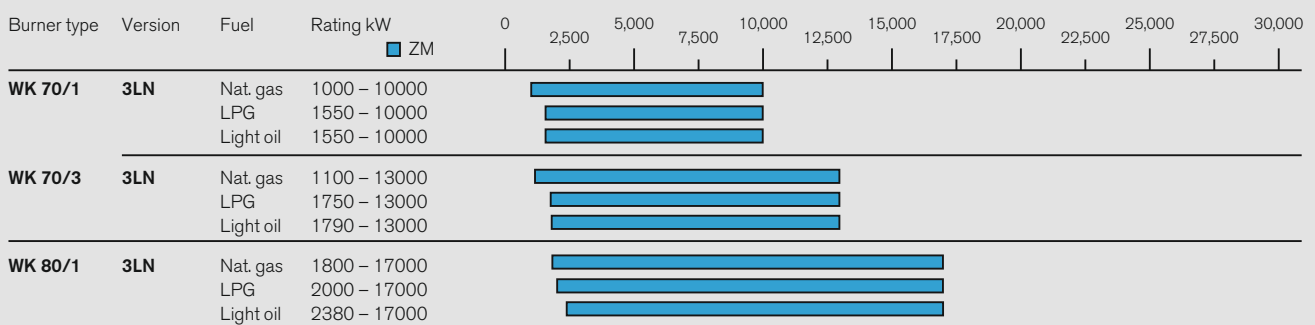

## Version 1SF

### WKGL and WKGMS dual-fuel burners

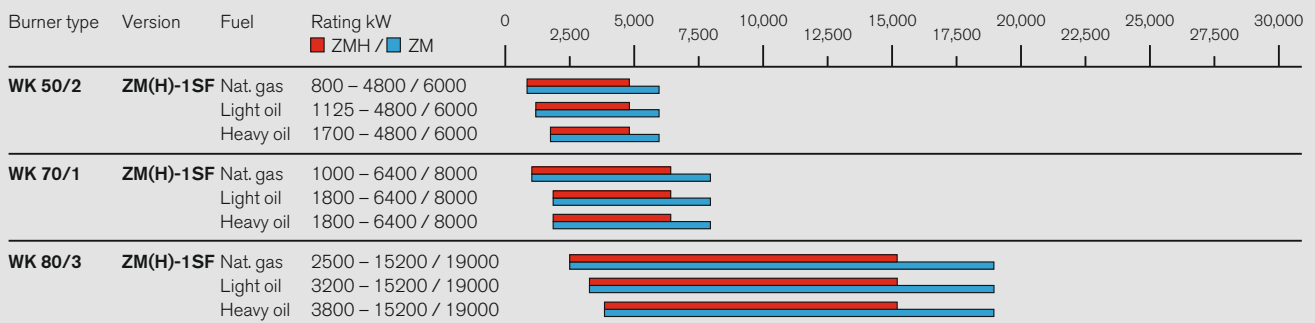

- Version ZM: Combustion air temperatures up to 20 °C
- Version ZMH: Combustion air temperatures up to 100 °C
- Version ZMH: Combustion air temperatures up to 250 °C

See the planning and installation handbook for fan selection and arrangement, gas valve trains, special equipment, technical data, and dimensions.

# Digital combustion management: Precise, simple, and reliable



Setting via the control and display unit

## Digital combustion management means optimal combustion figures, continuously reproducible setpoints, and ease of use.

Weishaupt WK-series burners are equipped as standard with electronic compound regulation and digital combustion management. Modern combustion technologies demand a precise and continually reproducible dosing of fuel and combustion air.

### Simple operation

Setting and control of the burner is achieved using a control and display unit. This is linked to the combustion manager via a bus system, enabling the user-friendly setting of the burner. The control and display unit has a clear text display with a choice of languages. An English/Chinese dual-screen version is available as an option should a Chinese-character display be desired.

### Flexible communication options

The integrated interface enables all necessary data and functions to be relayed to a master control system. If required, a modem can be installed to allow for remote operation, monitoring, and diagnosis.

### Measures for saving energy and increasing safety and reliability

**Electronic compound regulation** with the W-FM 100 and 200 combustion managers facilitates the extremely precise, hysteresis-free setting of the burner. The burner can be adjusted for ideal combustion figures throughout its entire capacity range. This reduces flue-gas losses and saves fuel.

**Variable speed drive** reduces electrical consumption and facilitates a soft start of the combustion air fan. The use of VSD also reduces noise emissions by a considerable amount.

**O<sub>2</sub> trim** saves fuel through a continual and extremely efficient optimisation of the combustion air. Different O<sub>2</sub> probes are available, providing suitable solutions for almost all fuels in applications with flue-gas temperatures below 300 °C.

**Combined CO/O<sub>2</sub> control** ensures an ultimate degree of safety. CO emissions are continually monitored and, if the defined limit is exceeded, the burner is operated with an increased amount of excess air for a short period of time before the O<sub>2</sub> trim returns the burner to its preset O<sub>2</sub> setpoint. Should external influences prevent a non-critical condition from being reached, then the burner will undergo a controlled shutdown.

## Digital combustion management makes burner operation simple and reliable:

- Ready-to-connect, tested, and preset unit
- One unit for all burner variants
- Precise control for optimal combustion figures
- Integral valve proving (gas-fired burners)
- Integral capacity controller/ analogue signal convertor
- Clear text display with a large choice of languages for simple operation
- Flexible communication options thanks to a variety of interfaces (Modbus / Profibus)

Digital combustion management overview	W-FM 100	W-FM 200
Continuous operation > 24 h	●	●
Capacity control for temperature or pressure	Optional	●
Setpoint input (0)4-20 mA / 0-10 V (temperature/output)	Optional	●
O <sub>2</sub> trim with QGO20/21 O <sub>2</sub> probe		●
Combined CO/O <sub>2</sub> control		Optional
VSD		●
Flue gas recirculation (temperature compensated)		●
WK(G)MS 80 with gas ignition		●
WKMS 80 with light-oil ignition	●	●
SQM40/48/9... servomotors in electronic compound (max.)	x 4	x 6
W-FC 4.0 flame monitoring	●	●
W-FC 5.0/6.0 flame monitoring		●
Parallel burner firing (in conjunction with KS... controller)	Optional	●
Two gaseous fuels (also in combination with a liquid fuel)		●
Two liquid fuels with different calorific values	x 2 ●	x 2 ●

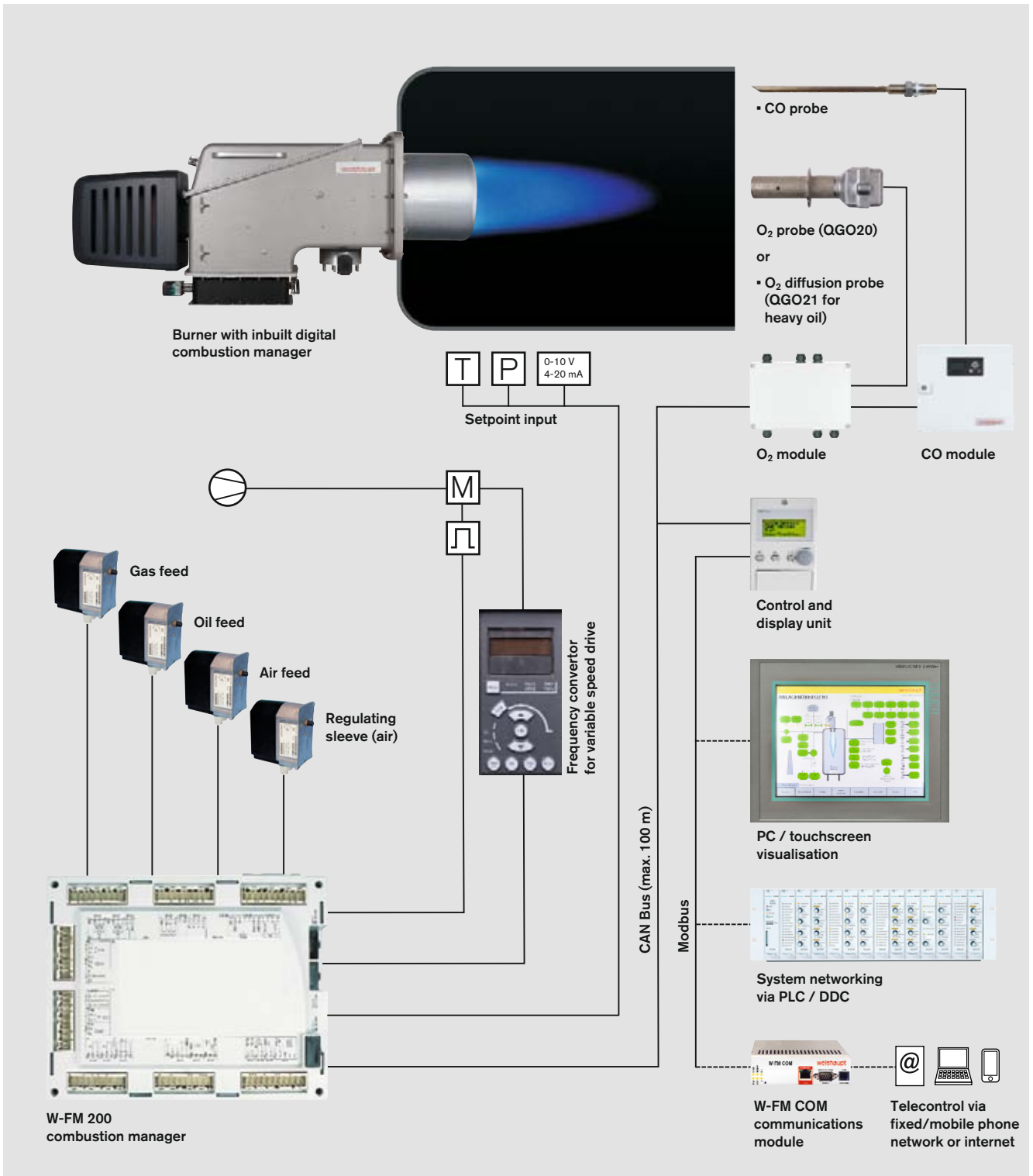

# Emissions reduced by the multiflam<sup>®</sup> principle

Weishaupt's multiflam<sup>®</sup> technology was designed for gas and dual-fuel burners. By using a patented 3LN mixing head, NO<sub>x</sub> emissions on WK-series burners can be reduced to extremely low levels.

Weishaupt has set an all-new benchmark, achieving levels below 80 mg/m<sup>3</sup> on gas and 120 mg/m<sup>3</sup> on oil, subject to the combustion-chamber geometry.

Weishaupt's multiflam<sup>®</sup> burners meet the world's toughest standards. In those countries with particularly stringent environmental legislation, such as Switzerland, multiflam<sup>®</sup> industrial burners are market-sector leaders.

At the heart of Weishaupt's multiflam<sup>®</sup> technology is a special mixing-assembly design which distributes the fuel among primary and secondary nozzles. This results in extremely efficient combustion thanks to recirculation of the flue gases directly at the mixing assembly.

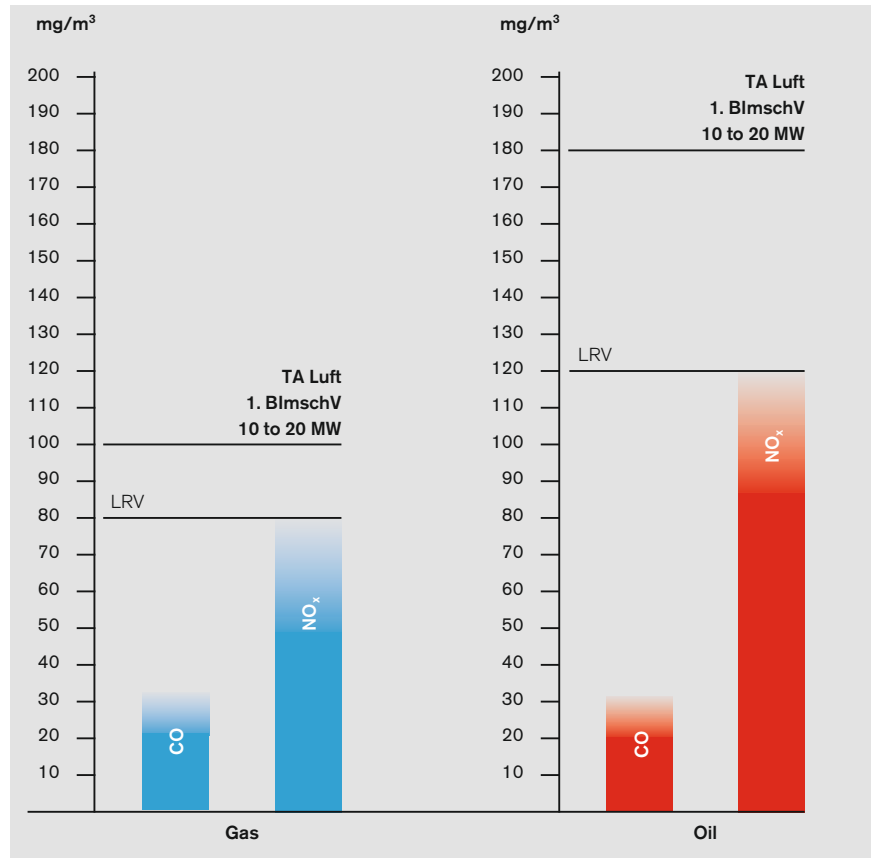

Typical emission levels for hot-water plant

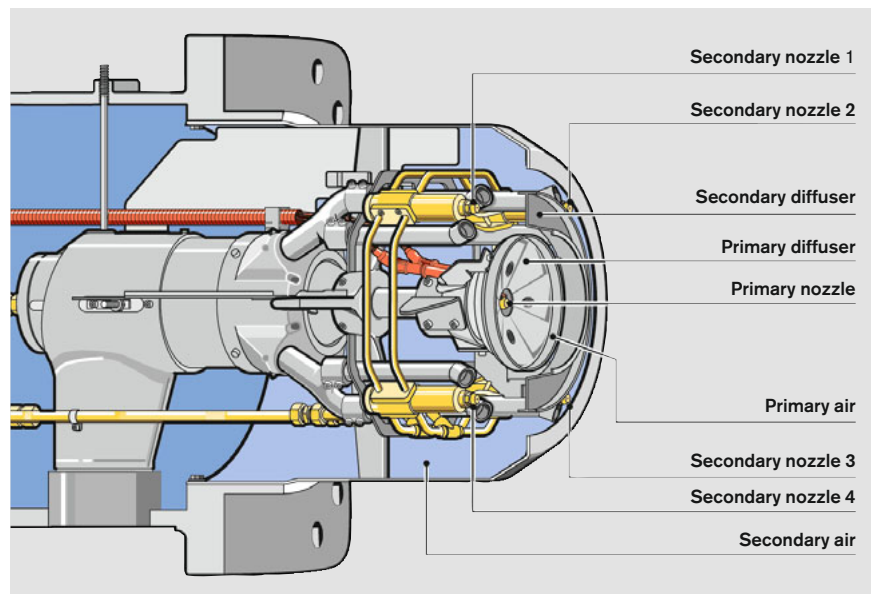

Cut-away illustration of the mixing assembly

# Flame monitoring for demanding safety requirements



Testing and optimisation using a software tool

**Weishaupt Flame Control (W-FC) is a reliable flame monitoring system designed for demanding safety requirements.**

**Version W-FC 4.0** is for plant with multiple burners firing from the same direction into a single combustion chamber. The W-FC assembly utilises flame frequency to monitor each flame separately via a load-independent on and off threshold for each fuel. The CFC3000 flame sensor functions in series with the QRA73 flame sensor on the W-FM 100/200 combustion manager.

**Version W-FC 5.0** is for plant with multiple burners firing from different directions into a single combustion chamber, and for process plant with

various flame sources. The W-FC assembly monitors each flame separately via a load-dependent switching threshold for each fuel. This guarantees a distinct differentiation from extraneous sources. The CFC3000 flame sensor functions in parallel with the QRA73 flame sensor on the W-FM 200 combustion manager. This convenient, load-dependent setting of the on and off thresholds rests upon the electronic VLoad module, which can be configured using software.

**Version W-FC 6.0** is to monitor flame stability on plant with flue-gas recirculation for extreme  $\text{NO}_x$  requirements. With this W-FM 200-based version, the QRA73 flame sensor monitors the flame while the CFC3000 controls the flue gas volume in accordance with the stability of the flame to ensure safe operating conditions. In this way, reliability of operation with optimal emissions is achieved under varying conditions. The VLoad module enables a load-dependent switching threshold to be tailored to the operational situation.

Simplified flue-gas recirculation is only designed for use with gaseous fuels.

**All versions meet EN 298 continuous operation requirements.**

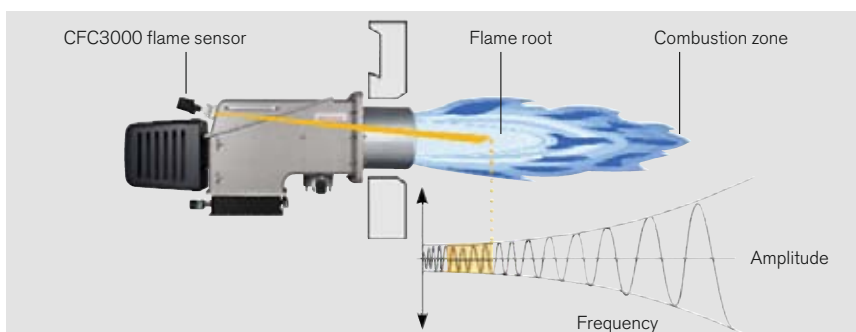
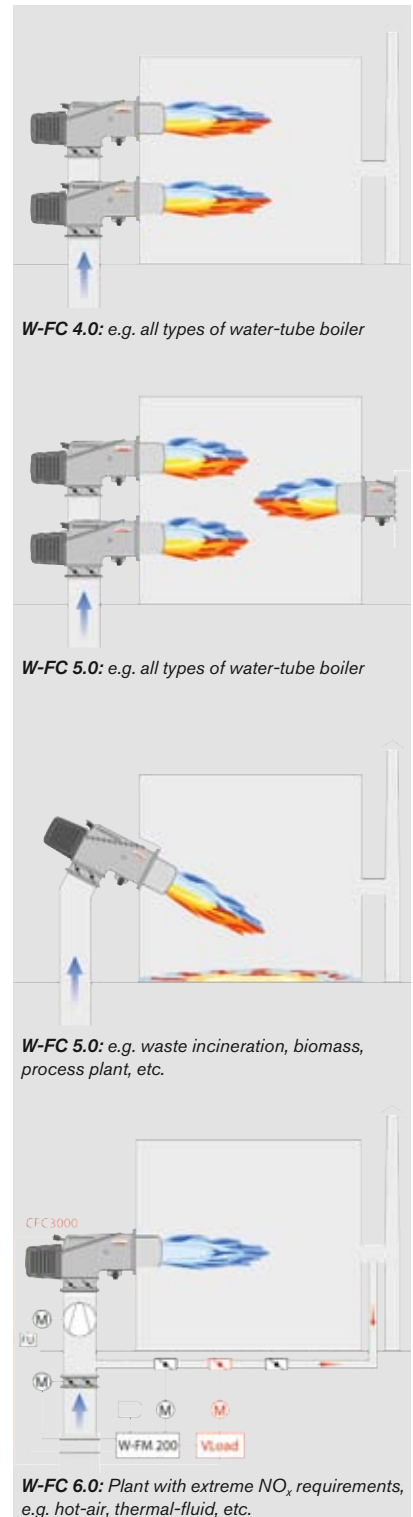

Alignment of the CFC3000 enables the detection range to be optimised

# Pilot-line variants for every fuel and rating

Weishaupt offers various pilot-line variants in order to ensure maximum reliability of ignition.

## Variant A

**Standard ignition for gaseous and liquid fuels on WK 40-70.**

The pilot line feeds a controlled amount of gas to the ignition electrodes. Liquid fuels are ignited directly by the ignition electrodes

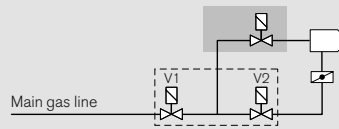

Pilot-line ignition, variant A

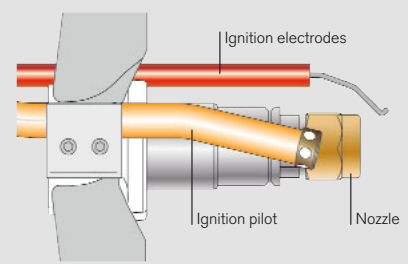

Variant A with pilot-line ignition

## Variants B to D

**Optimal ignition when firing highly viscous liquid fuels, using a specially designed, high-quality ignition burner**

The particularly low rating of ~ 30 kW makes reliable operation with natural gas and bottled LPG possible. Flame monitoring is via a separate ionisation probe, which necessitates the use of a W-FM 200 combustion manager.

This reliable solution was developed especially for heavy and special fuel oils with widely varying characteristics. It is also suitable for extreme ignition conditions, such as cold-starting plant with preheated combustion-air temperature.

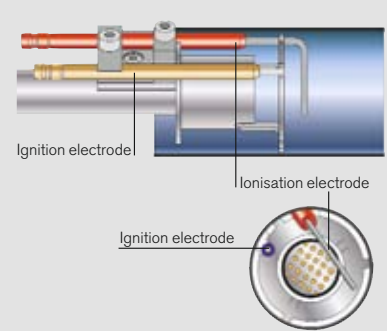

Pilot-line variants B to D with ignition burner

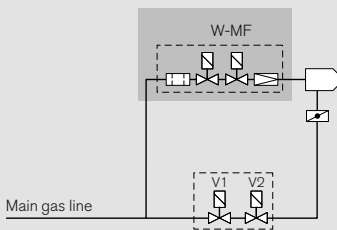

Pilot line with ignition burner, variant B

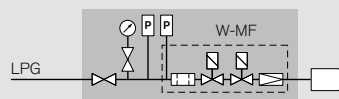

Pilot line with ignition burner, variant C

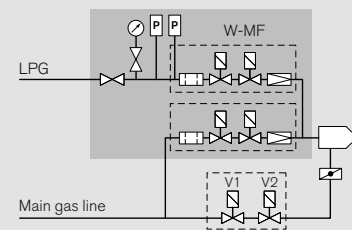

Pilot line with ignition burner, variant D

	WK...40 – 70 WKL/WKGL 80	WKMS 80 < 17.5 MW	WKGMS 80 < 17.5 MW	WKMS 80 > 17.5 MW	WKGMS 80 > 17.5 MW
Pilot-line variant A	●	● <sup>1)</sup>	● <sup>1)</sup>		
Pilot-line variant B			● <sup>1) 2)</sup>		● <sup>1) 2)</sup>
Pilot-line variant C		● <sup>2)</sup>		● <sup>2)</sup>	
Pilot-line variant D			● <sup>2)</sup>		● <sup>2)</sup>

Accessories for variants C to D



**Complete set** comprising:

- ① LPG pressure regulator, 11/33 kg
- ② Hose rupture protection
- ③ 3 m hose

<sup>1)</sup> Price reduction on application

<sup>2)</sup> W-FM 200 combustion manager required

● Standard

● Optional



# Fuel systems

## Oil burners

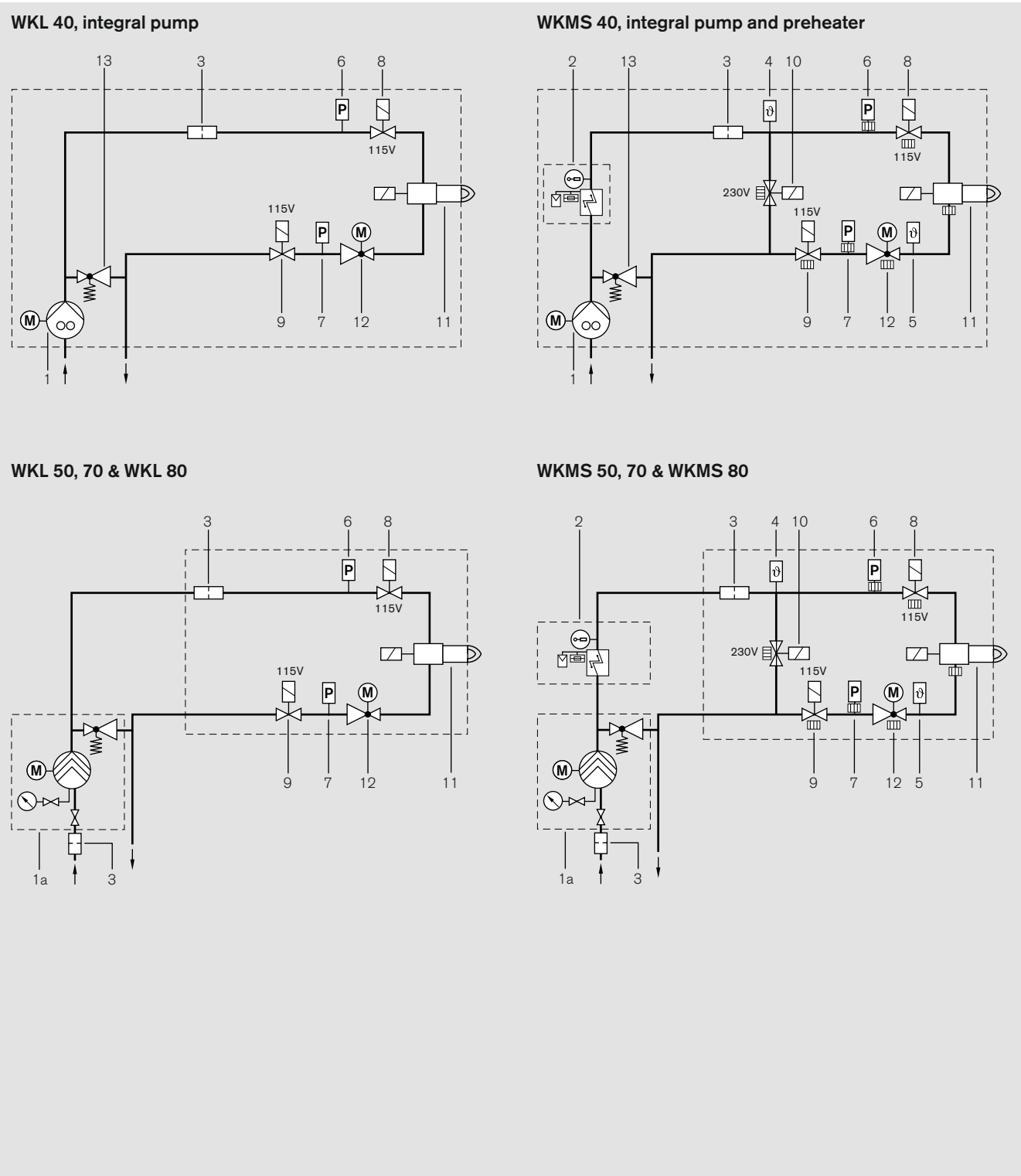

**WKL multiflam®**

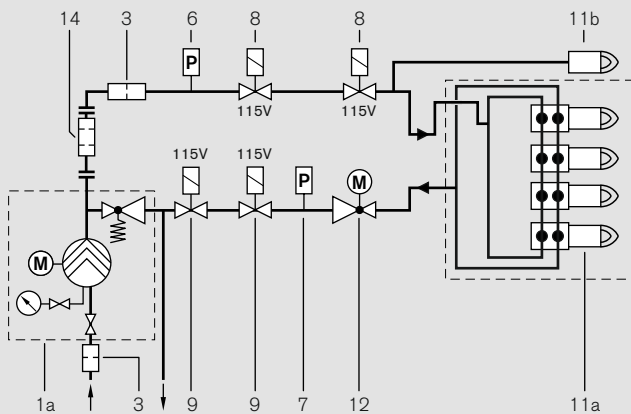

**WKMS 80 with light-oil ignition**

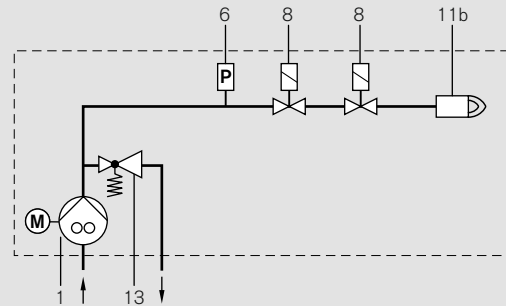

Complete unit mounted on burner

**WKMS 80 with LPG ignition**

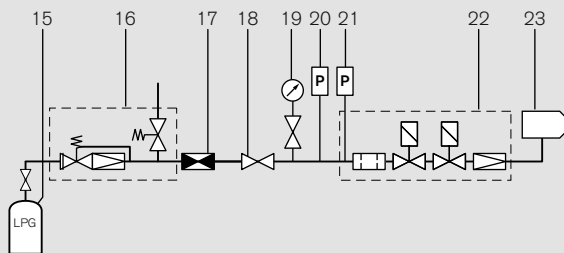

Gas pilot line for oil firing

- 1 Oil pump
- 1a External pump station with pressure maintenance
- 2 Oil preheater
- 3 Filter
- 4 Temperature sensor in supply
- 5 Temperature sensor in return
- 6 Low-pressure switch
- 7 High-pressure switch
- 8 Solenoid valve in supply (fitted in the direction of flow)
- 9 Solenoid valve in return (fitted against the direction of flow)
- 10 Bypass solenoid valve (normally open)
- 11 Solenoid valve assembly
- 11a Nozzle head with secondary nozzles
- 11b Nozzle head with primary nozzle
- 12 Oil regulator
- 13 Pressure regulating valve
- 14 Filter (immediately next to burner)
- 15 LPG tank (by others)
- 16 LPG pressure regulator (accessory)
- 17 Hose rupture protection (accessory)
- 18 Ball valve
- 19 Pressure gauge with push-button valve
- 20 High-gas-pressure switch
- 21 Low-gas-pressure switch
- 22 W-MF multi-function assembly
- 23 Burner

# Fuel systems

## Gas and dual-fuel burners

**A** Gas-side, WKG(L) 40 – 80, WKGMS 40 – 70  
Versions ZM / NR / 1LN / 3LN / 1SF

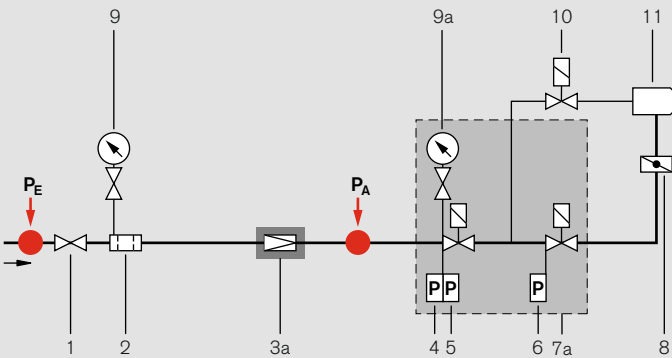

**B** Gas-side, WKG(L) 80  
Versions NR / 3LN / 1SF

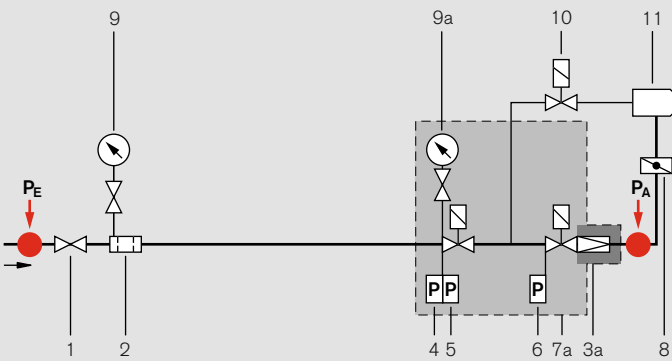

**C** Gas-side, WKG(L) 40 – 80, WKGMS 40 – 70  
Versions ZM / NR / 1LN / 3LN / 1SF

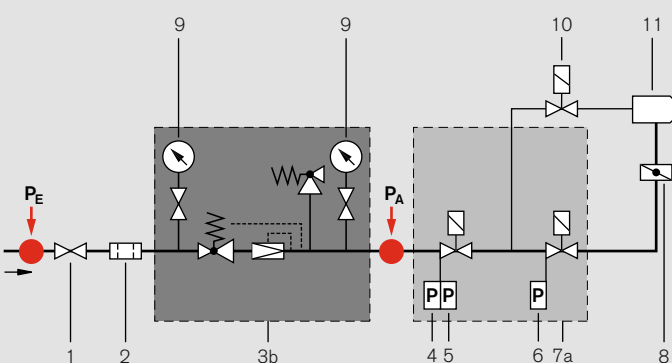

				A	B	C
				Low-pressure supply with FRS governor	Low-pressure supply with SKP regulator on VGD assembly	High-pressure supply with High-pressure regulator
WK burner size	Nominal val-train size	Gas shut-off assembly type				
40 50 70 80				$P_E \leq 300$ mbar	$P_E \leq 300$ mbar	$P_E$ 1 / 1.5 / 2.5 / 3 / 4 bar <sup>1)</sup>
				$P_A \leq 200$ mbar	$P_A \leq 250$ mbar	$P_A \leq 210 / 240$ mbar <sup>1)</sup>
	1 1/2"	W-MF 512		●		●
	2"	DMV 525/12		●		●
	DN 65	DMV 5065/12		●		●
	DN 80	DMV 5080/12		●		●
	DN 100	DMV 5100/12		●		●
	DN 125	VGD 40.125		●	●	●
	DN 150	VGD 40.150		●	●	●

● Optional SKP25 for WK 80 burners  
 $P_E$  = Pressure before ball valve     $P_A$  = Regulated pressure

<sup>1)</sup> See accessories list for special 4 - 10 bar regulators and spring selections > 240 mbar

WKG 40 and 70, version LN, gas-side

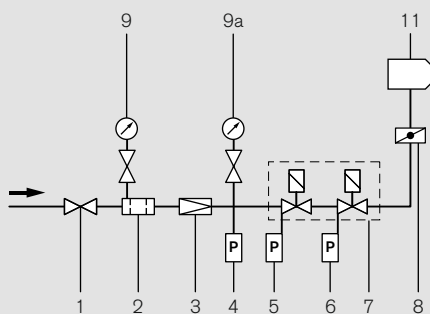

WKGMS 80, gas-side

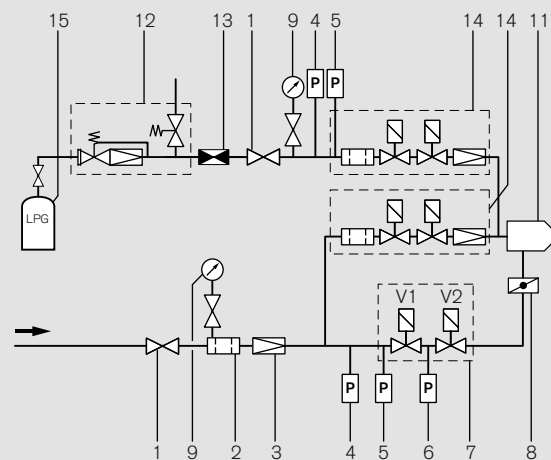

Oil and gas-fired with gas pilot line, pilot line switchable between natural gas and LPG  
 (optional, standard: oil = LPG pilot line, Gas = natural gas pilot line before V1)  
 For other pilot variants see page 16

**Layout of the valve train**

On boilers with hinged doors, the valve train must be mounted on the opposite side to the boiler-door hinges.

**Compensator**

To enable a tension free mounting of the valve train, the fitting of a compensator is recommended.

**Support of the valve train**

The valve train should be properly supported in accordance with the site conditions. See the Weishaupt accessories list for various valve-train-support components.

- 1 Ball valve
- 2 Gas filter
- 3 Pressure regulator
- 3a Low-pressure regulator
- 3b High-pressure regulator inc. SSV / SBV
- 4 High-gas-pressure switch
- 5 Low-gas-pressure switch
- 6 Valve-proving pressure switch
- 7 Double solenoid valve
- 7a Double solenoid valve inc. connecting parts
- 8 Gas butterfly valve
- 9 Pressure gauge with push-button valve
- 9a Pressure gauge with push-button valve (accessories)
- 10 Pilot-line solenoid valve (except LN version)
- 11 Burner
- 12 LPG pressure regulator (accessory)
- 13 Hose rupture protection (accessory)
- 14 W-MF multi-function assembly
- 15 LPG tank (by others)

# Combustion test chamber at the Schwendi Research & Development Institute

