



Illustrative example::

VGD20

VGD4x / VRD4x

Double gas valves

VGD2...
VGD4...
VRD4...

- Class A double gas valve for integration into gas trains
- Safety shutoff valves conforming to EN 161 in connection with SKPx5 actuators
- VGD20 and VGD4x are suitable for gases in the I...III range
- VRD4x only: Suitable for slightly aggressive biogases and recycling gases
- Double gas valves in connection with SKPx5s open slowly and close rapidly
- Sizes 1" ... DN 150
- The double gas valve must be equipped with 2 SKPx5 actuators
- For supplementary data sheets on SKPx5 actuators, refer to the *Mechanical design* chapter
- Models for the USA on request

The VGD20 / VGD4x / VRD4x and this Data Sheet are intended for use by OEMs which integrate the VGD20 / VGD4x / VRD4x in their products!

The VGD20 / VGD4x / VRD4xs are primarily suitable ...

- On gas-fired combustion plant
- In gas trains in connection with forced draft gas burners

The VGD20 / VGD4x / VRD4x is used as:

- Shutoff valves (in connection with SKP15 actuators)
- Control valves with shutoff feature (in connection with SKP25, SKP55 or SKP75 actuators). VRD4xs combined with SKPx5s with pressure control function (SKP25, SKP55, and SKP75) must be considered in consultation with Siemens for usability in connection with the intended recycling gases.

All VGD20 / VGD4x / VRD4xs can be combined with any type of SKPx5.

VRD4xs are also designed for slightly aggressive, dry gases. Gases according to G262 (German specification) such as biogases, landfill gases, sewage gases, other recycled gases, process gases, and air.

The chemical composition and aggressiveness of each biogas or recycled gas is different, not constant, and dependent on several factors.

The aggressiveness of the gas notably increases:

- as the hydrogen sulfide content H₂S increases
- with the moisture content of the gas, condensation is not permitted inside the VRD4x

In consultation with Siemens, users must decide whether the materials used for the VRD4xs are suitable for the intended types of recycling gas. These gases can vary in terms of both their composition and the respective concentration of the components. As a result, it is not possible to make any warranties or definitive statements regarding service life. An assessment should be carried out to determine the suitability of the gas used.

For safety reasons, we strongly recommend

- the installation of a valve proving device
- a visual inspection of the VRD4xs at intervals of 6 to 12 months
- SKP25, SKP55, and SKP75 must be mounted in an upright position because the controller should be at the highest point

Supplementary documentation

Product type	Product name	Type of documentation	Documentation number
QPLx5	Gas pressure switch	Data sheet	N7221
SKPx5	Actuator	Data sheet	N7643

Warning notes



To avoid injury to persons, damage to property or the environment, the following warning notes must be observed!

It is not permitted to open, interfere with or modify the double gas valves!

Any opening of the valve, replacement of parts or modifications to the original product is the user's responsibility and is done at his own risk.

- All activities (mounting, installation and service work, etc.) must be carried out by qualified staff
- Any double gas valves that experience a fall or shock must not be put into operation, as this can adversely affect the safety functions even if they do not exhibit any external signs of damage
- In combination with the valve proving system from other manufacturers, the suitability must be checked individually for the plant
- Unsuitable gases or gas components lead to a loss of the safety shutoff function
- It must not be possible for foreign bodies/particles to enter the VGD20 / VGD4x / VRD4x, as this could have an adverse effect on the safety shutoff function
- Gases with concentrations of >0.1% for H₂S and NH₃ are only permissible in connection with VRD4x
- Condensation is not permitted in the VGD20/VGD4x/VRD4x. If not observed, the safety functions are no longer ensured
- In connection with SAX31, the VGD20/VGD4x/VRD4x must not be used as a safety device. Closing does not take place according to EN 151

Mounting notes

	<ul style="list-style-type: none">• Ensure that the relevant national safety regulations are complied with• The SKPx5 can be mounted or replaced while the gas valve is under pressure• For SKP25: The impulse pipe (pressure feedback) can be connected directly to the valve output on the VGD20/VGD4x/VRD4x• For SKP75: The impulse pipe (pressure feedback) must be connected to the gas pipe after the VGD20/VGD4x/VRD4x at a distance of at least 3 to 5 times the nominal size (DN) of the straight pipe section
Gasket/tightness	<ul style="list-style-type: none">• Check to make certain that the bolts of the AGF10 are properly tightened and afterwards check to ensure that the gas valve is tight when all components are connected• The O-rings or flange gaskets must be fitted between the AGF10 and the VGD20 / VGD4x / VRD4x• Recommendation in the case of exposure to external moisture: Set of gaskets AGA66 (IP65 kit)
Mounting position	The permissible mounting position of the SKPx5 used must be observed (refer to Data Sheet N7643).
Direction of flow	The gas must flow in the same direction as the arrow on the VGD20 / VGD4x / VRD4x.
Function	The VGD20 / VGD4x / VRD4x is normally closed and opens when the SKPx5 opens. It is recommended to mount an SKPx5.xx1xx to notify the CLOSED position of the associated VGD20 / VGD4x / VRD4x.
VGD20	<ul style="list-style-type: none">• Mount the electrohydraulic SKP15 on the inlet side and the SKPx5 with integrated controller (SKP25, SKP55 or SKP75) preferably on the outlet side of the VGD20 / VGD4x / VRD4x• When mounting the VGD20 in the gas train, 2 AGF10 flanges are required• When replacing a VGD20 on existing AGF10s, new O-rings must be mounted• To prevent cuttings from falling into the VGD20, first mount the AGF10 on the pipes. Then clean the parts before installing the VGD20

Mounting instructions

AGF10 onto VGD20



Note

Installation of the AGF10.

The AGF10s can also be mounted offset by 90°.

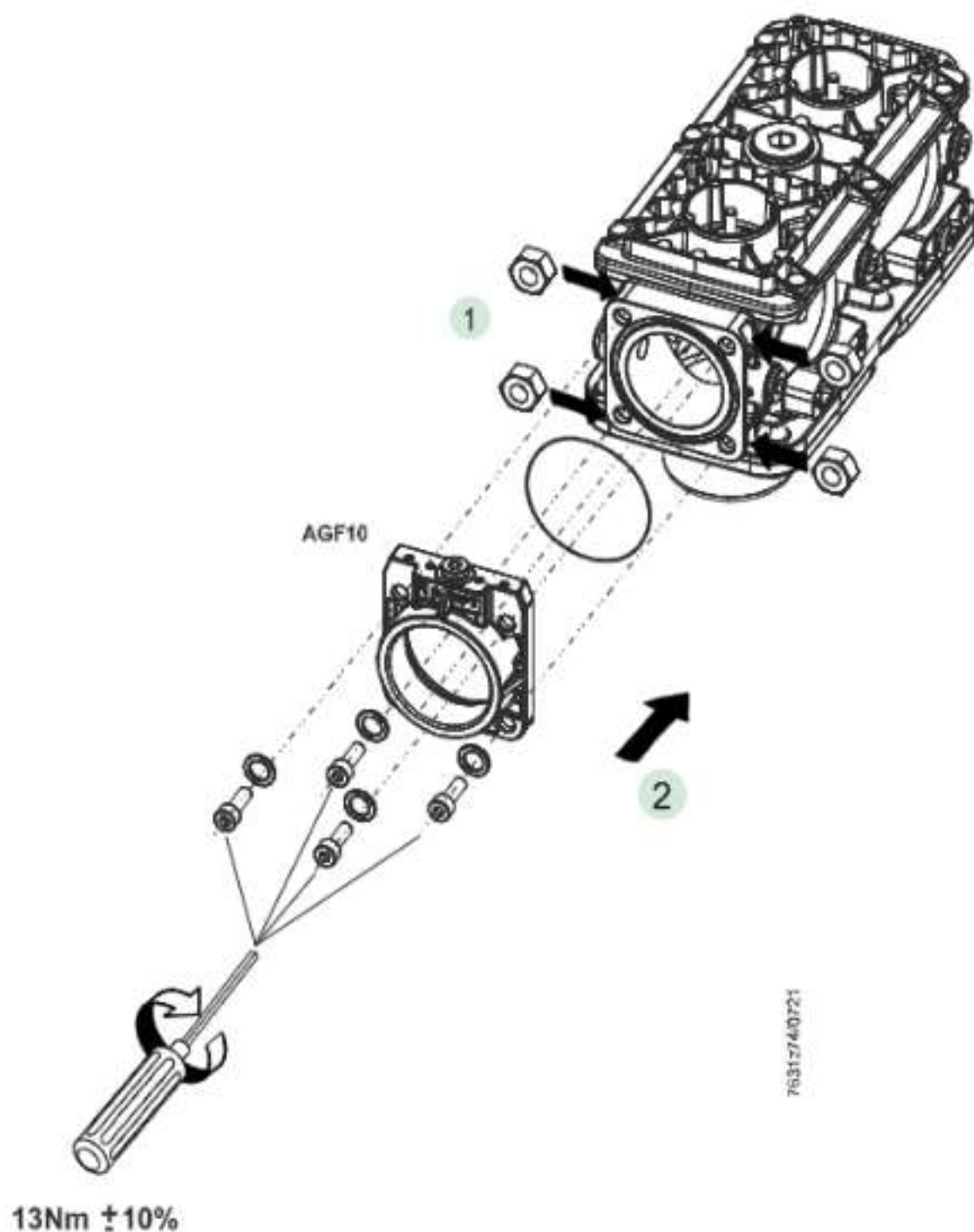

AGA41/AGA51 onto
VGD20

Scope of delivery of the AGA92 (also refer to the *Accessories* chapter):

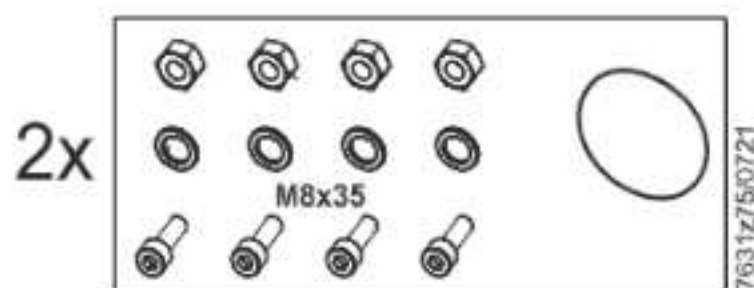

Caution!

Conversion or replacement of the VGD20

For the conversion of the 'NEW' VGD20 to the existing AGA41/AGA51 flanges, new O-rings and new M8 x 35 screws or the AGA92 service kit are required.

QPLx5 onto VGD20

QPL15

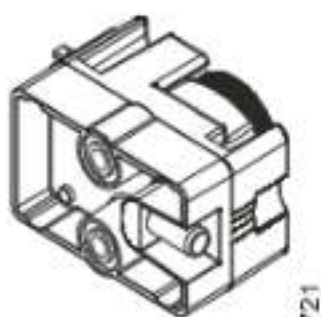

QPL25

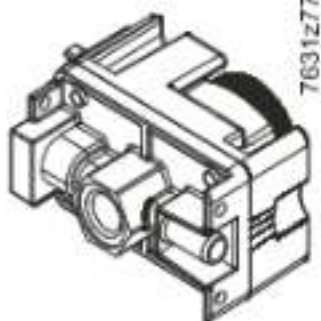

1

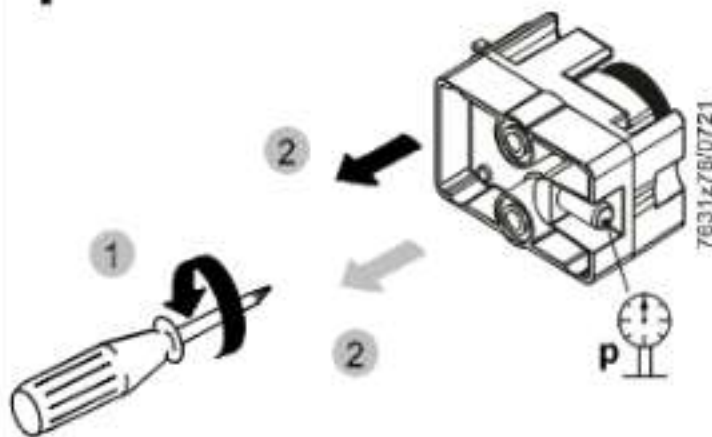

2a

QPL15 / VGD20

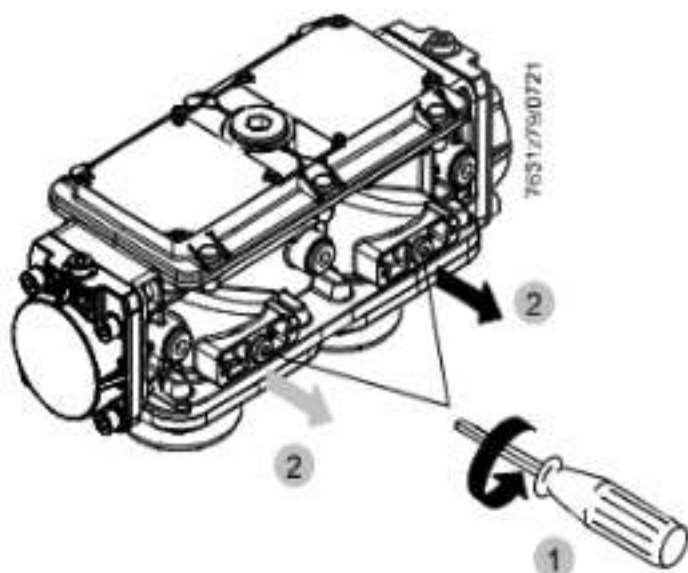

3a

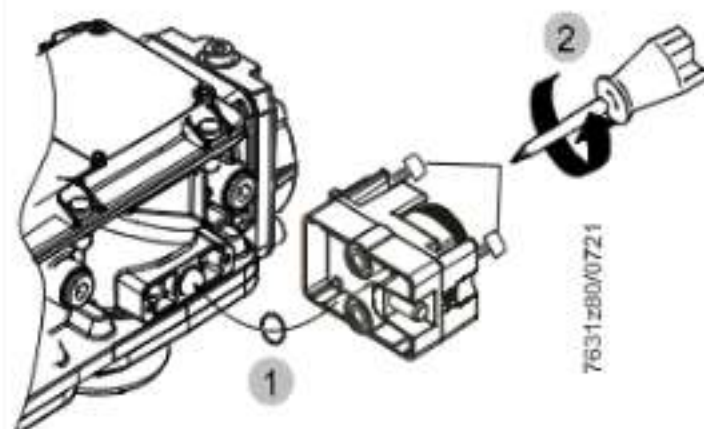

QPLx5 onto AGF10

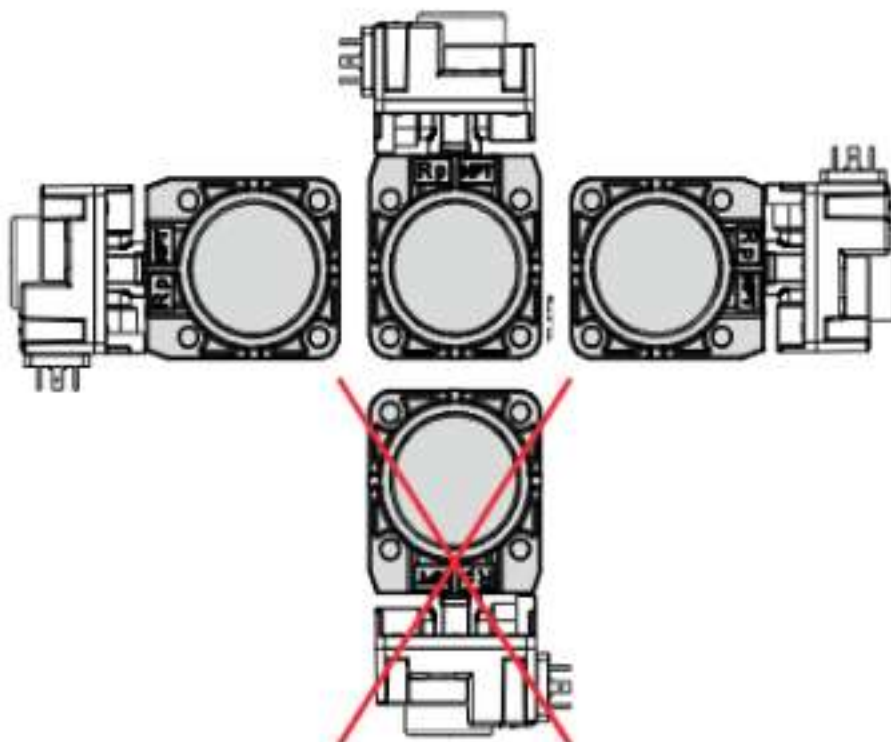

Example: Possibilities of fitting the QPL15 with O-ring to the VGD20.xx11

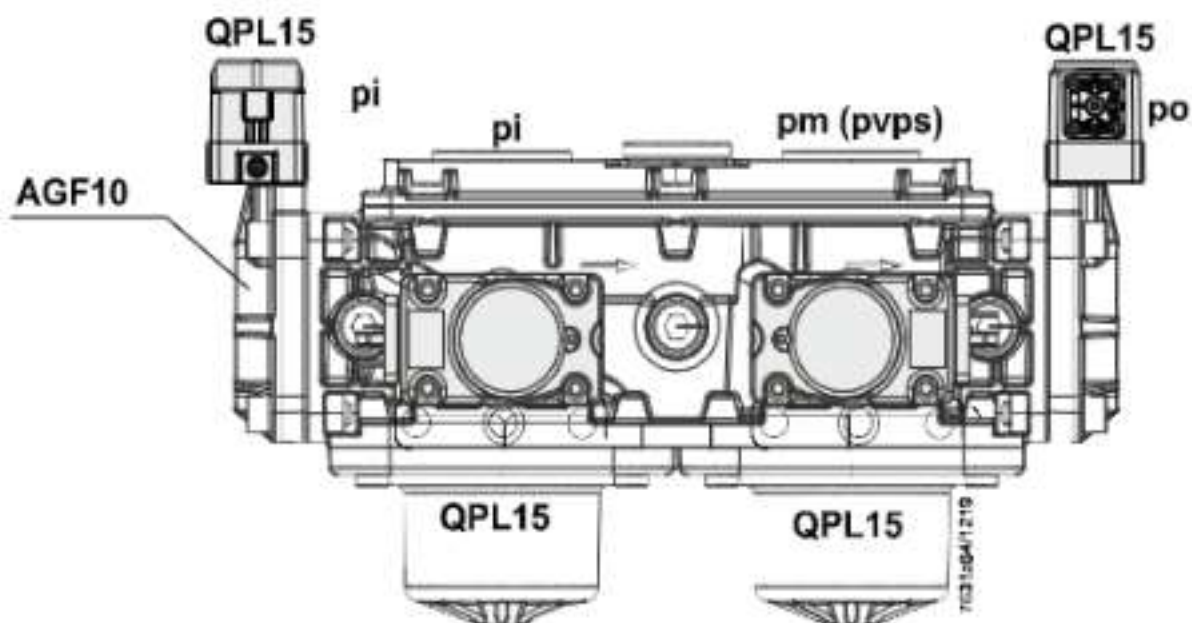

Example: Possibilities of fitting the QPL25 with nipple to the VGD20.xx3 Rp $\frac{1}{4}$ "...1/8"

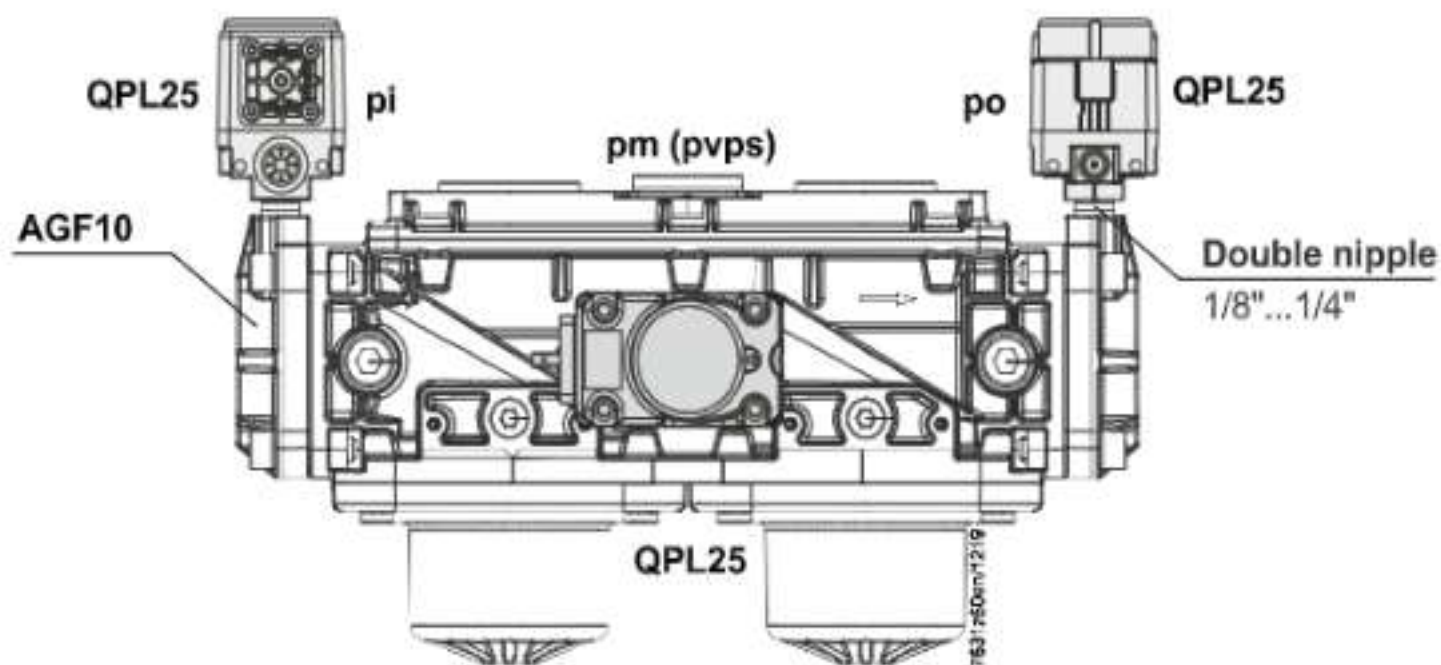

VGD4x

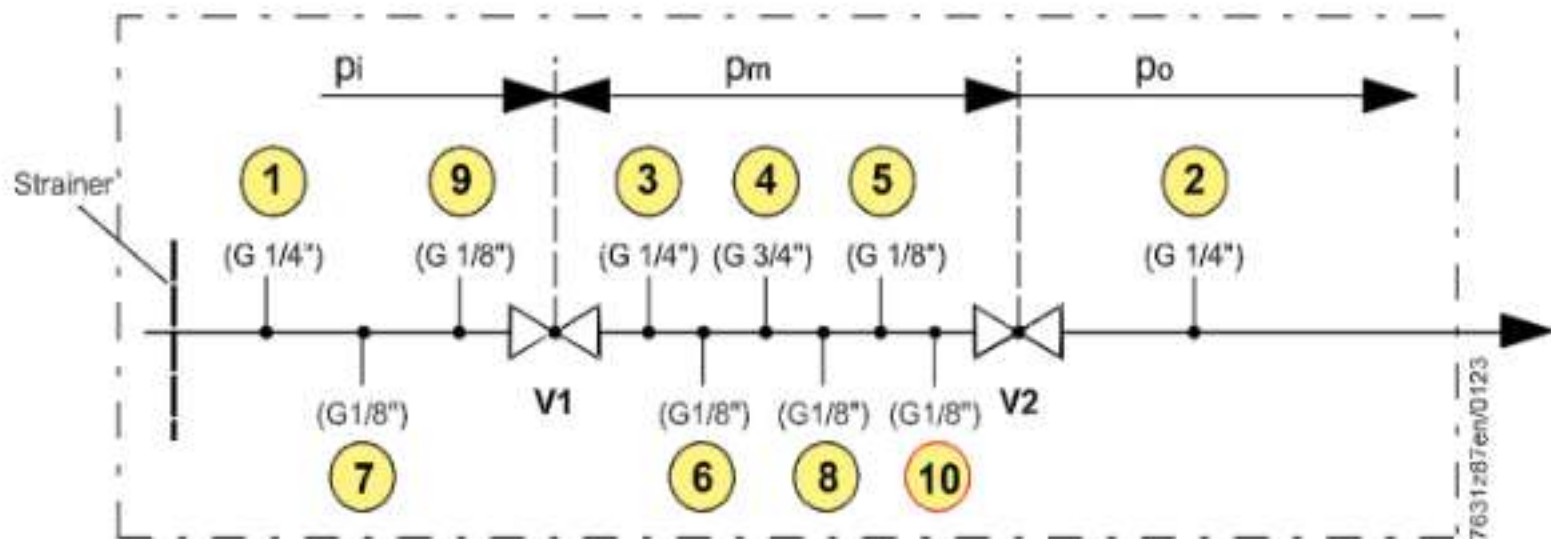
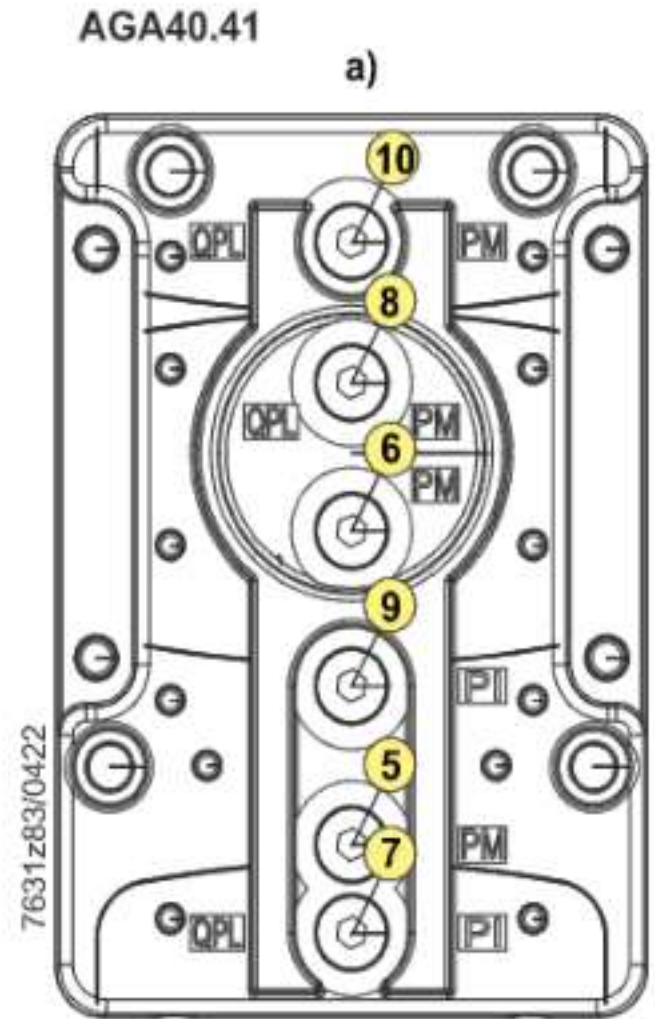
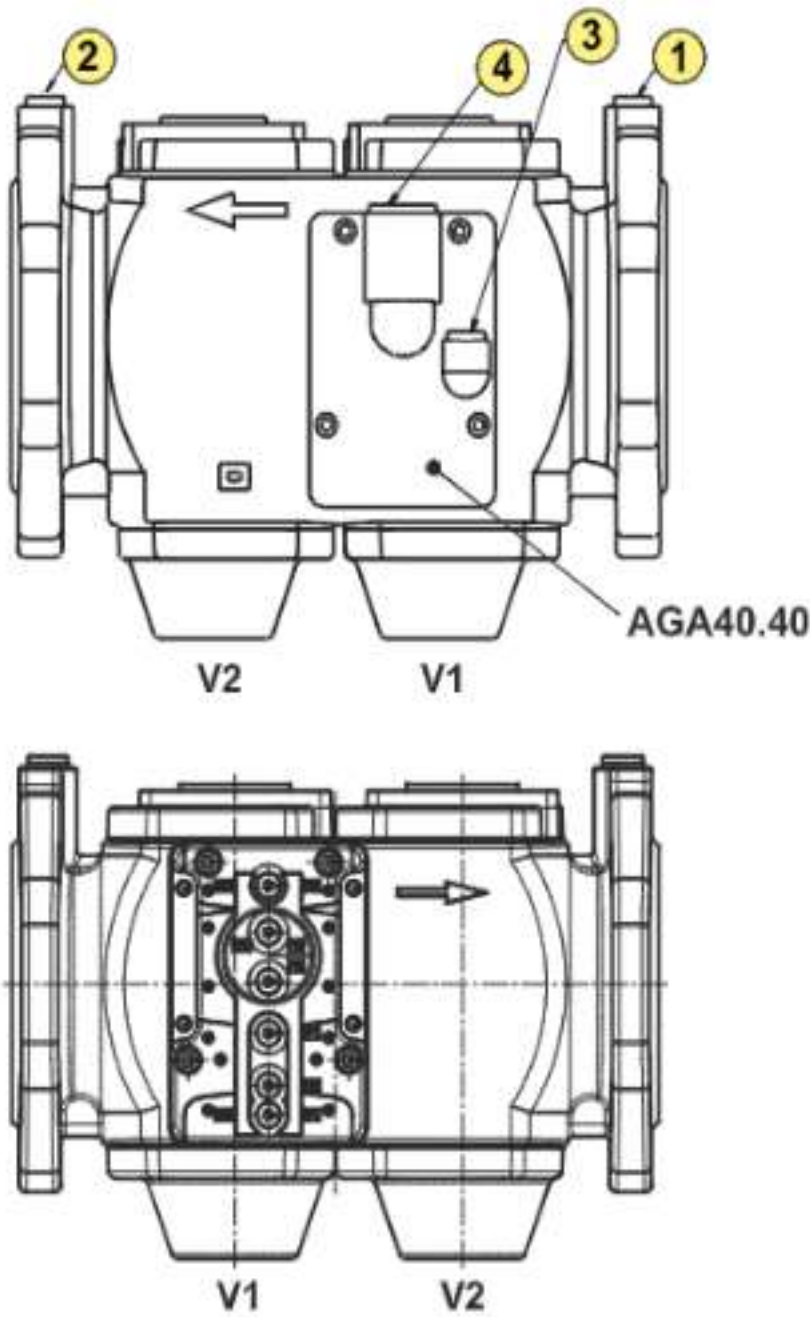

- key
- pi V1 inlet pressure
 - pm Pressure between V1 and V2
 - po V2 outlet pressure
 - (2) Possible pressure impulse connection when an SKP25 is mounted on V2
 - (2) or (3) Possible pressure impulse connections when an SKP25 is mounted on V1
 - (3) Enables the pressure control of the pilot



SKP55/SKP75 only

The impulse pipe (pressure feedback) must be connected to the gas pipe after the VGD20 / VGD4x / VRD4x at a distance of at least 3 to 5 times the nominal size (DN) of the straight pipe section

VG4x
Options

VG40

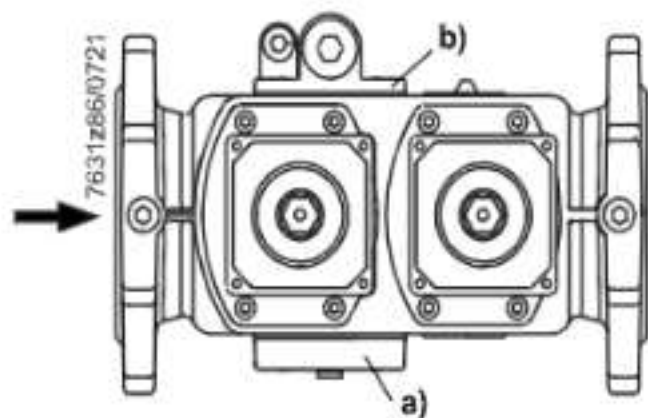

VG41

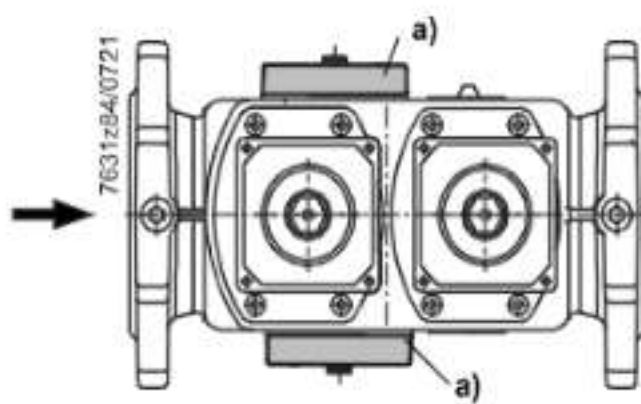

VG40.xxxL

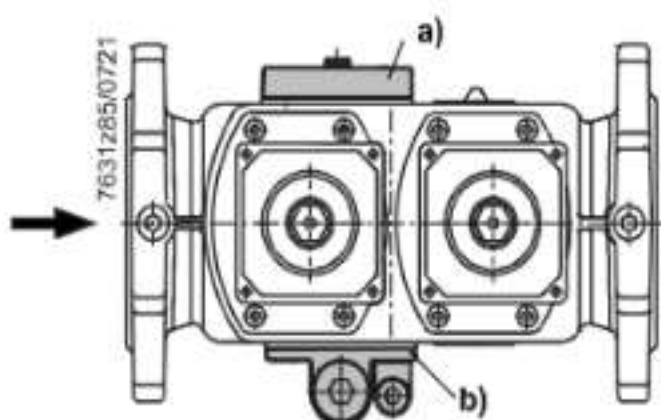

Key

- a) AGA40.41 pressure switch connecting plate
- b) AGA40.40 pilot gas connecting plate

Example: Possibilities of fitting the QPLx5 to the VGD4x

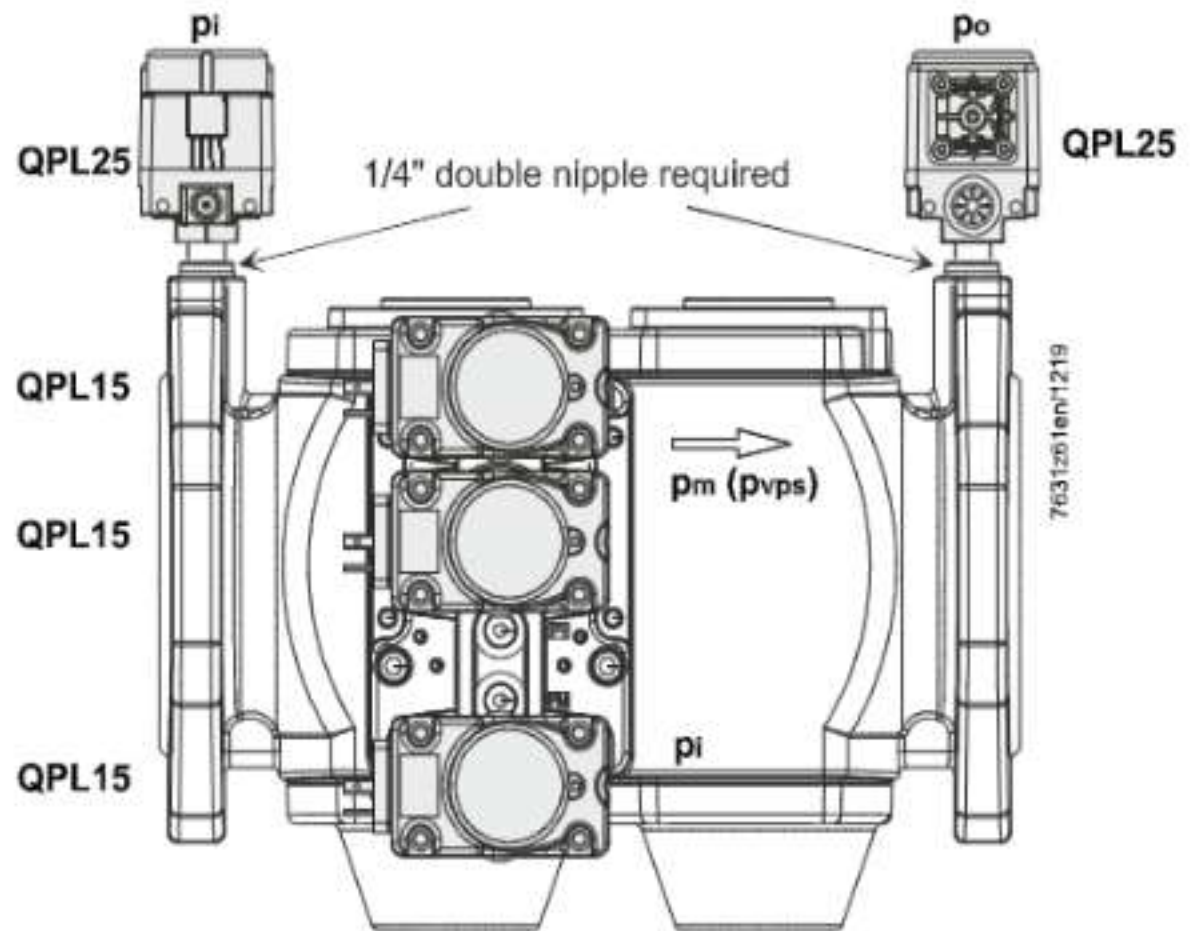

Legend

- pi = inlet pressure
- po = outlet pressure
- pm = mid-chamber pressure
- pvps = valve proving check

Example: Mounting options of VGD4x/VRD4x (equipped here with SKP15 and SKP25)

Variant 1: AGA40.41 with mounted QPL15

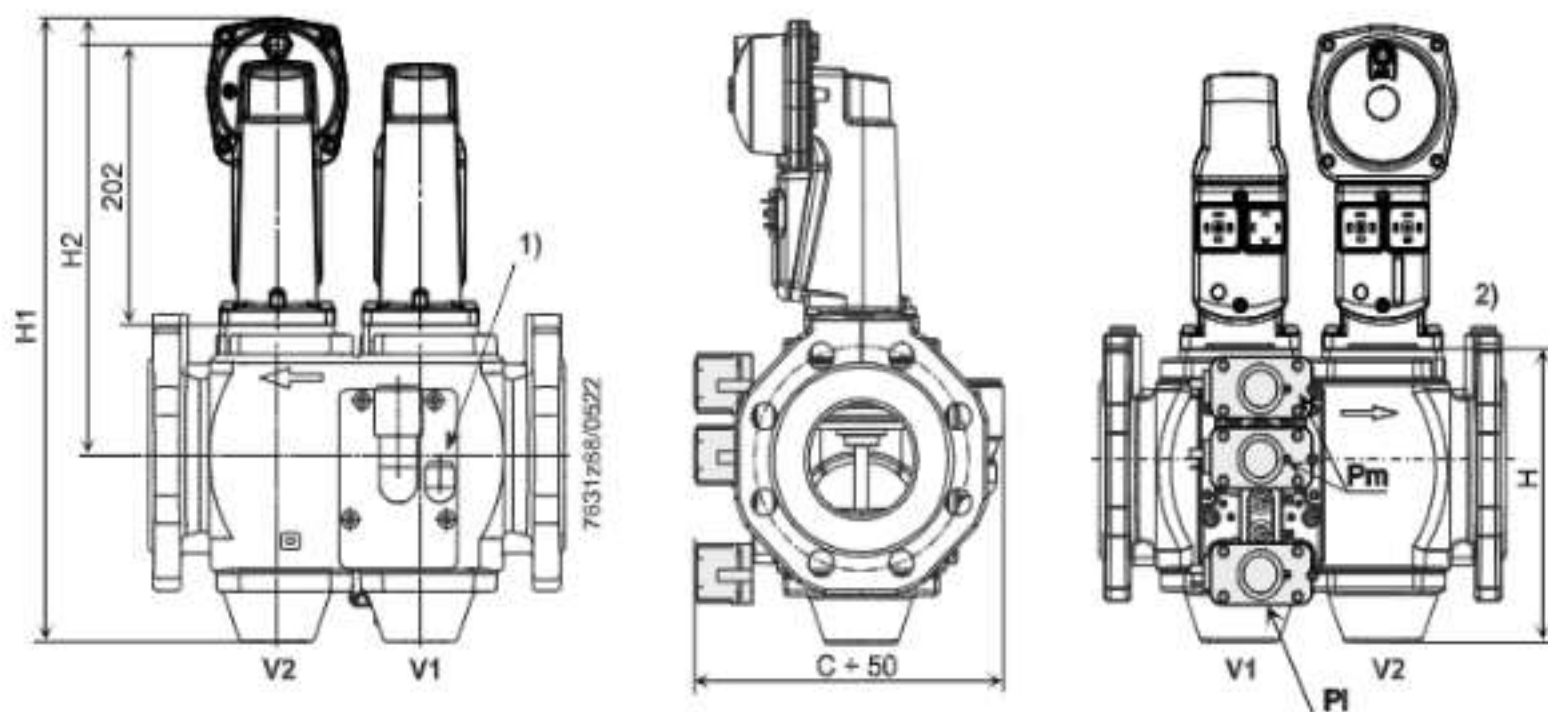

- 1) Impulse pipe connection if an SKP25 is mounted on V1 and pilot pressure control is required
- 2) Impulse pipe connection, if an SKP25 is mounted on V2

Caution!

Ingress of dirt and dirt particles while mounting.



To prevent the ingress of dirt and dirt particles, the following precautions must be observed:

- The yellow plastic caps of the VGD4x/VRD4x gas valve outlet must not be removed while laying (machining) the pipes
- The upstream and downstream pipes must be cleaned after being laid
- Before commissioning, it is essential to ensure that no dirt particles have remained that could enter the VGD4x/VRD4x
- The yellow plastic caps of the gas valve outlet may only be removed just before mounting the VGD4x/VRD4x. Only then may the VGD4x/VRD4x be mounted carefully

Type	SKPx5	SKP15		SKP25		SKP55		SKP75	
	C	H1	H2	H1	H2	H1	H2	H1	H2
VGD40.040 / VGD40.040L / VGD41.040 VRD40.040	168	382	267	415	300	427	312	463	348
VGD40.050 / VGD40.050L / VGD41.050 VRD40.050	175	382	267	415	300	427	312	463	348
VGD40.065 / VGD40.065L / VGD41.065 VRD40.065	195	388	270	421	303	433	315	469	351
VGD40.080 / VGD40.080L / VGD41.080 VRD40.080	204	412	280	445	313	457	325	493	361
VGD40.100 / VGD40.100L / VGD41.100 VRD40.100	228	443	298	476	331	488	343	524	379
VGD40.125 / VGD40.125L / VGD41.125 VRD40.125	256	491	316	524	349	536	361	572	397
VGD40.150 / VGD40.150L / VGD41.150 VRD40.150	335	521	333	554	366	566	378	602	414

Mounting instructions (continued)

Mounting options for the VGD4x/VRD4x

Variant 2: Example (not binding)

Valve proving 'A'

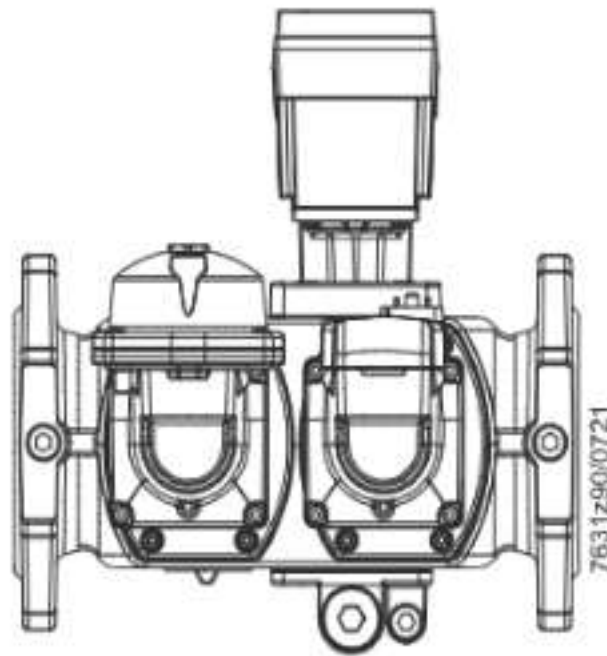

Variant 3: Example (not binding)

Valve proving 'B' (only up to nominal size DN125) and QPLx5 (pi) below

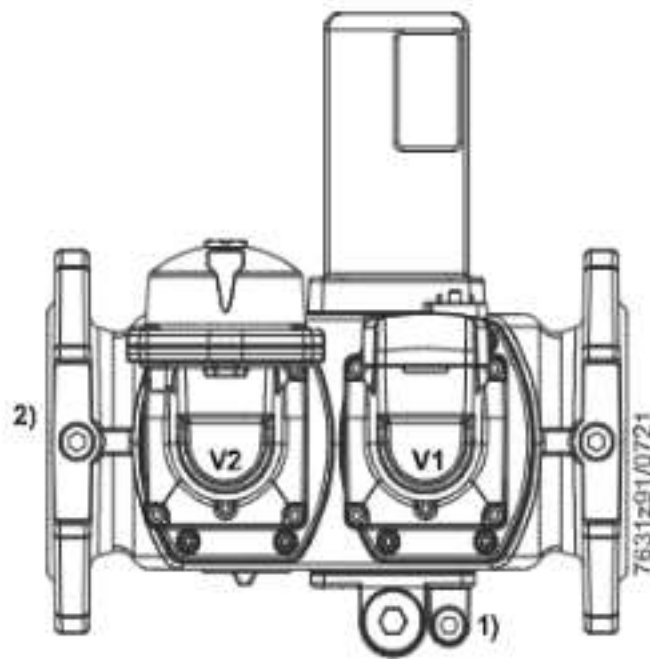
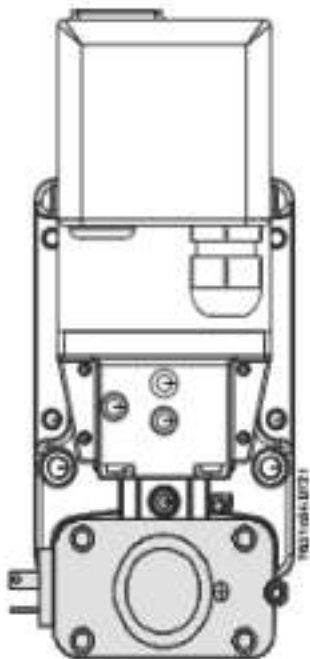

Note

Both the opportunities for use and functionality of the system with valve proving A and B must be checked on a plant-specific basis!

Mounting instructions (continued)

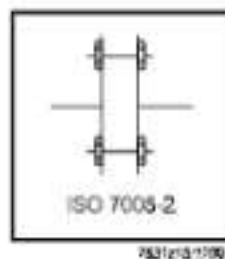

Maximum torques / flange connection (stud screw)

- Tighten locking screws and connecting screws in the appropriate manner
- Note the material pairing of 'aluminum-steel'

DN40... 50	M16 x 65 (DIN 939) ----- 50 ±5 Nm	DN125	M16 x 75 (DIN 939) ----- 160 ±16 Nm
DN65... 100	M16 x 65 (DIN 939) ----- 80 ±5 Nm	DN150	M20 x 80 (DIN 939) ----- 160 ±16 Nm

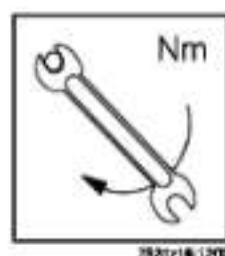

Maximum torques / system accessories

M4	M6	M8	G1/8	G1/4	G3/4
3 Nm	7 Nm	15 Nm	8 Nm	15 Nm	35 Nm

Standards and certificates



Applied directives:

- Gas Appliances Regulation (EU) (EU) 2016/426



Note!

The VGD20/VGD4x/VRD4xs are only type-tested and approved in combination with the SKPx5. Refer to Data Sheet N7643 and certificates for SKPx5.

The relevant valid edition of the standards can be found in the SKPx5 declaration of conformity.



EAC Conformity mark (Eurasian Conformity mark)



UKCA conformity mark (UK compliance)



China RoHS

Hazardous substances table:

<http://www.siemens.com/download?A6V10883536>





Note

Suitability of natural gas-hydrogen mixtures or pure hydrogen.

When using the VGD20/VGD4x/VRD4x, a manufacturer's declaration can be provided on request.

Standards and certificates (cont'd)

Approvals in combination with the SKPx5

Type			
VGD20.403	●	●	●
VGD20.503	●	●	●
VGD20.2511	●	---	●
VGD20.3211	●	---	●
VGD20.4011	●	---	●
VGD20.4011C	●	---	●
VGD20.4011Y	●	---	●
VGD20.5011	●	---	●
VGD20.5011A	●	---	●
VGD20.5011C	●	---	●
VGD20.5011Y	●	---	●
VGD40.040	●	●	●
VGD40.040L	●	---	●
VGD40.050	●	●	●
VGD40.050L	●	---	●
VGD40.065	●	●	●
VGD40.065L	●	---	●
VGD40.065J	●	---	●
VGD40.080	●	●	●
VGD40.080L	●	---	●
VGD40.080J	●	---	●
VGD40.100	●	●	●
VGD40.100L	●	---	●
VGD40.125	●	●	●
VGD40.125L	●	---	●
VGD40.150	●	●	●
VGD40.150L	●	---	●
VGD41.040	●	---	●
VGD41.050	●	---	●
VGD41.065	●	---	●
VGD41.080	●	---	●
VGD41.100	●	---	●
VGD41.125	●	---	●
VGD41.150	●	---	●
VRD40.040	---	●	●
VRD40.050	---	●	●
VRD40.065	---	●	●
VRD40.080	---	●	●
VRD40.100	---	●	●
VRD40.125	---	●	●
VRD40.150	---	●	●

Life cycle

The combination double gas valve and actuator have a designed lifetime* of

Nominal sizes	Burner startup cycles
≤25 DN	200.000
25...80 DN	100.000
80...150 DN	50.000

under use of gases to EN 437 (or DVGW specification G260).

This lifetime is based on the endurance tests in the standard EN 161. A summary of the conditions has been published by the European Control Manufacturers Association (Afecor) (www.afecor.org).

The designed lifetime is based on use of the double gas valve and actuator according to the manufacturer's data sheet. After reaching the designed lifetime in terms of the number of burner startup cycles, or after the corresponding usage time, the double gas valve and actuator must be checked and/or replaced by authorized personnel.

The limit values of EN 161 must be used to check the necessary tightness requirements. If the double gas valve is equipped with a valve proving system in accordance with EN 1643, manual testing is not required.

* The designed lifetime is not the warranty time specified in the Terms of Delivery.

The use in gases beyond the scope of EN 437 / G260, such as G262, can result in a limited lifetime.

Service notes

- Each time a gas valve has been replaced, check to ensure that the VGD20 / VGD4x / VRD4x operates correctly and that it is tight both internally and externally
- Siemens double gas valves may **only** be repaired by Siemens repair centers or by personnel with explicit authorization from Siemens



Caution!

The QPLx5 also has to be replaced when replacing a valve. It is recommended to replace the QPLx5 after over 50,000 cycles or a service life of 10 years due to the designed lifetime for gas pressure switches according to AFECOR. It is not recommended to reinstall these, even if the seals on the valve have been replaced.

Disposal notes

Local and currently valid legislation must be observed.

Mechanical design

Strainer A strainer made of stainless steel is fitted in the inlet and protects the VGD20 / VGD4x / VRD4x, seat, and disc – as well as downstream devices – against dirt.

AGF10 to VGD20 The AGF10s have an 1/8" sealing plug. They are internally threaded and supplied as separate items together with the necessary accessories, such as bolts, nuts, and gaskets. All of the connection thread dimensions for the AGF10 can be optionally fitted to a VGD20. Each VGD20 requires 2 AGF10s.

VGD20 Sectional view of VGD20

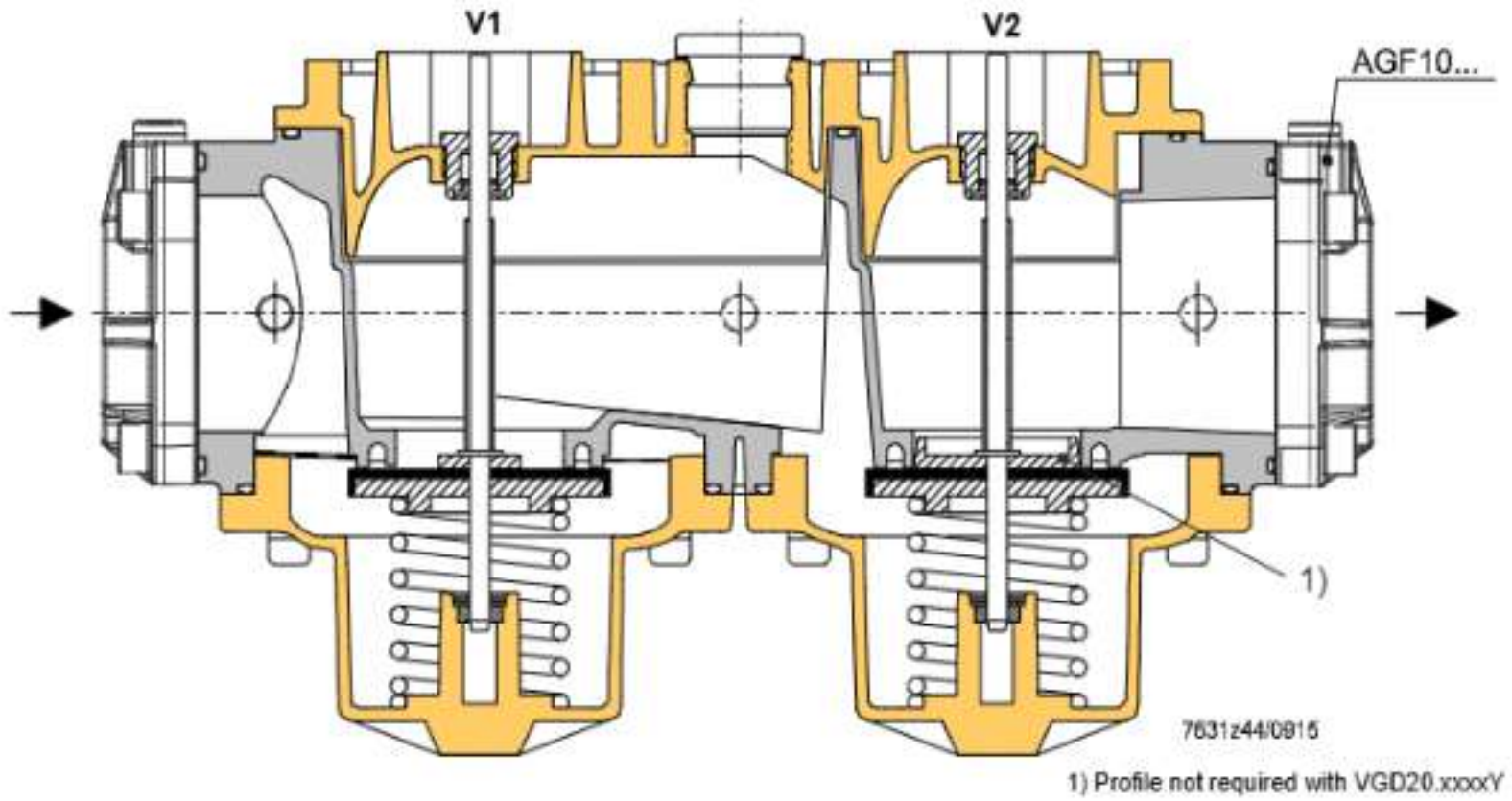

Application example VGD20 with SKP15 (mounted on V1) and SKP75 (mounted on V2)
Shown without AGF10

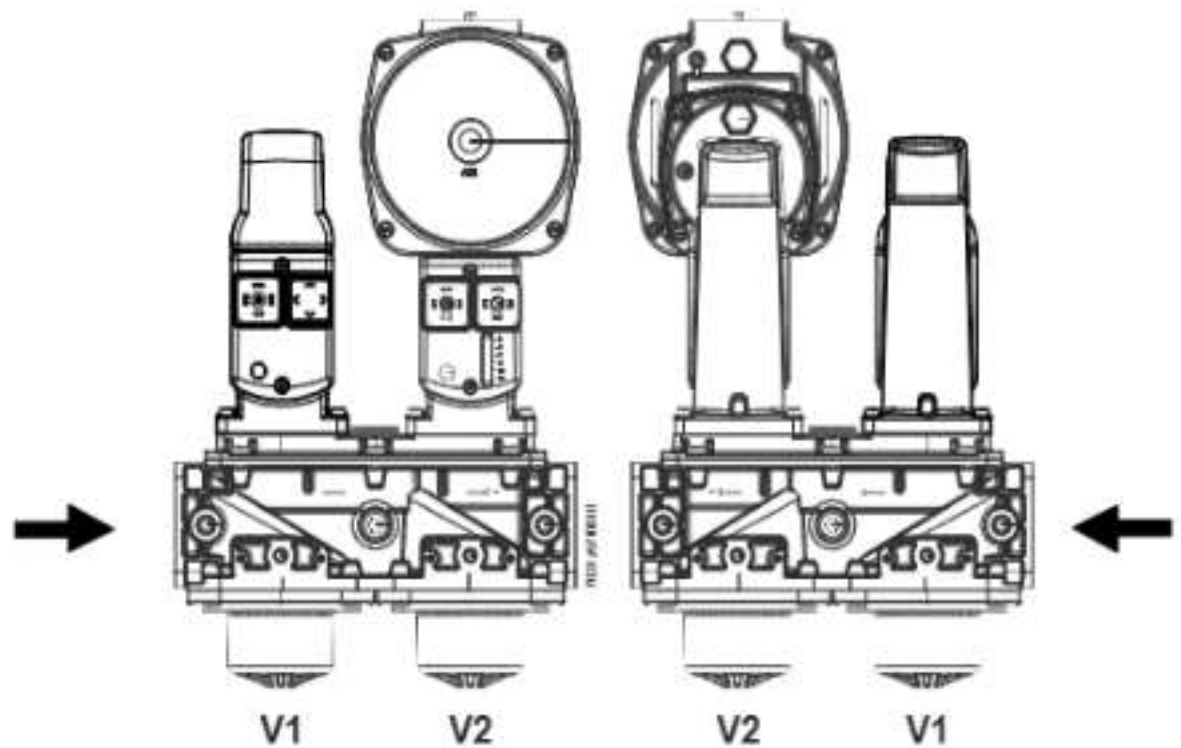

Mechanical design (cont'd)

VGD4x / VRD4x



The VGD4x / VRD4xs are double-seat poppet valves. The 1/4" impulse connection on the AGA40.40 for valve **V1**, or the impulse connection on the VGD4x / VRD4x outlet flange for valve **V2**, can be connected to the impulse connection of the mounted constant pressure governor SKP25.

The VGD4x/VRD4xs are normally closed in connection with the SKPx5.

Closing springs

Each double seat uses one pair of springs. The spring forces act selectively on the valve seats.

AGA40.41

The AGA40.41  facilitates the attachment of a number of commercially available pressure switches or valve proving devices. The AGA40.40  and AGA40.41 can be fitted on either side of the valve.

VGD40 / VRD40

Sectional view of VGD40 / VRD40

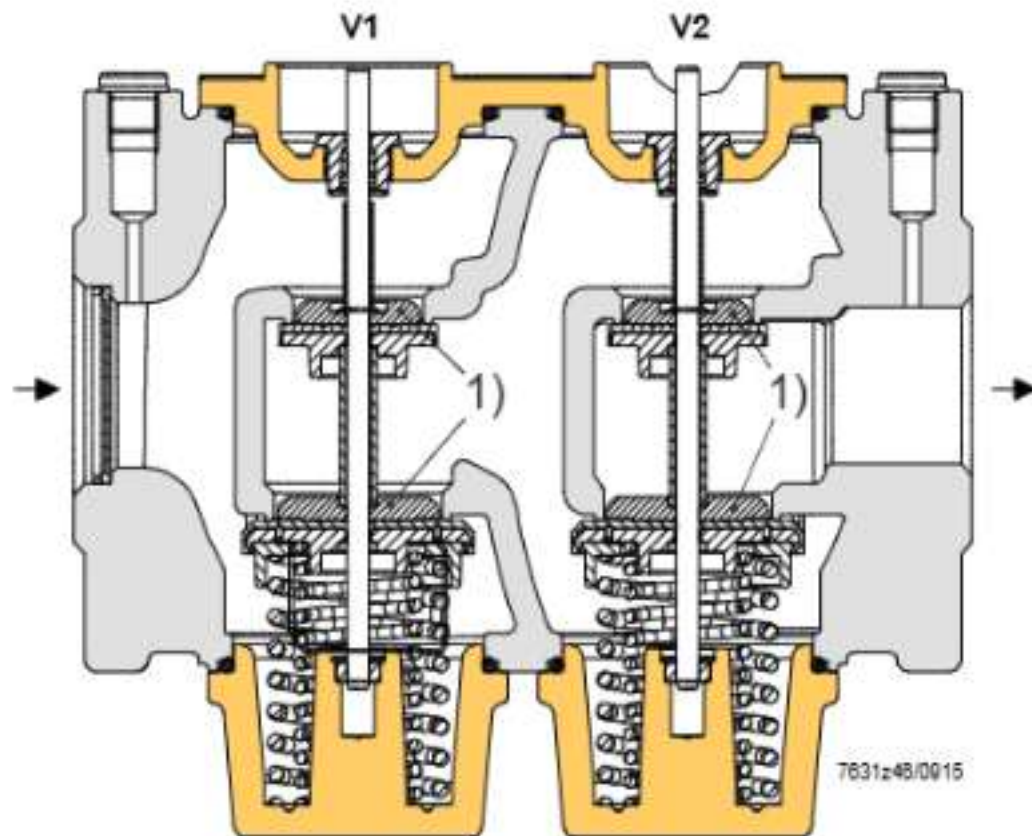

1) Profile not required with VGD41.xxxx

Application example

VGD40.080 with SKP15 (mounted on valve **V1**) and SKP25 (mounted on valve **V2**).

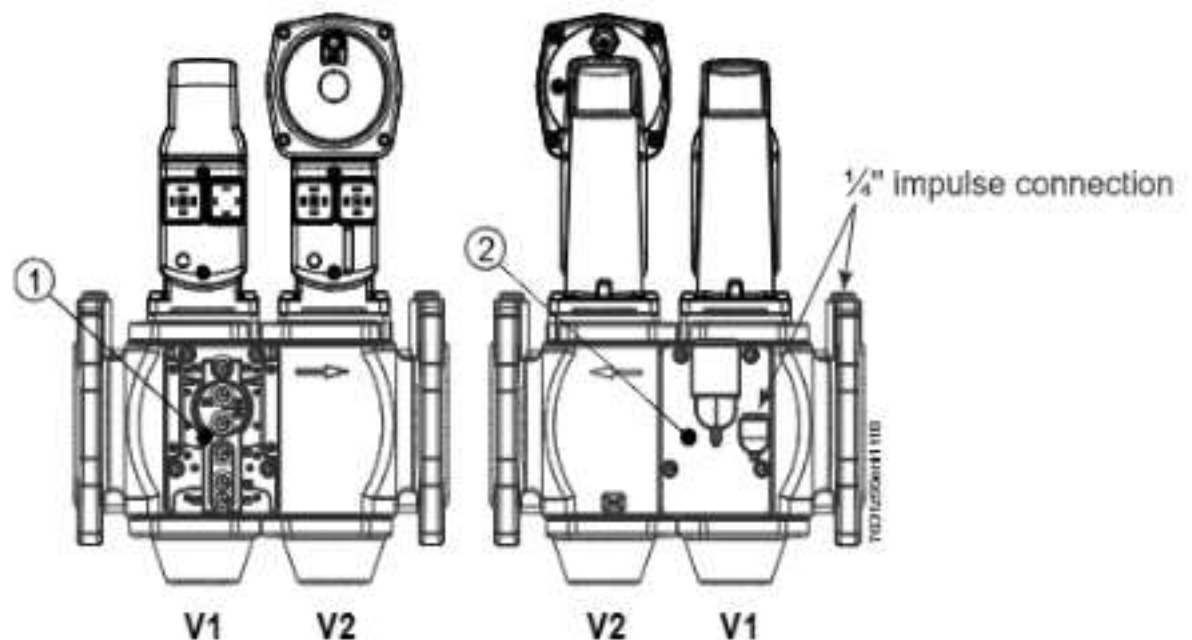

SKPx5

The VGD20 / VGD4x / VRD4xs can be combined with the following SKPx5s:

Product no.	Data Sheet	Function
SKP15	N7643	ON/OFF
SKP25	N7643	ON/OFF with constant pressure control/zero pressure control
SKP25.7 with SQS37	N7643	ON/OFF with pressure control, predefined setpoint adjustable via electrical signal
SKP55	N7643	ON/OFF with differential pressure control, signal input → differential pressure
SKP75	N7643	ON/OFF with fuel / air ratio control, signal input → static pressure

VRD4x only:

- SKP15
- Other actuators (SKP25, SKP55, and SKP75) after gas suitability test
-

Note



When using VRD4x biogas valves, it is recommended to use SKPx5s with an end switch (CPI), e.g., SKPx5xx1xx.

Type summary (other types of valves on request)

VGD20

Nominal size	Flow rate at $\Delta p = 1 \text{ kPa}$ m^3/h air	With 3 internally threaded connections		With 11 internally threaded connections		With 11 internally threaded connections Without valve seat profiling (V2) for faster gas permeability		With 11 internally threaded connections With specific valve seat profiling (V2) *) with stroke adjustment at the valve seat (V1) (Inlet side)	
		Article no.	Type	Article no.	Type	Article no.	Type	Article no.	Type
1"	25	---	---	\$55590-G103-A100	VGD20.2511	---	---	---	---
1 1/4"	46	---	---	\$55590-G101-A100	VGD20.3211	---	---	---	---
1 1/2"	85	BPZ.VGD20.403	VGD20.403	BPZ.VGD20.4011	VGD20.4011	BPZ.VGD20.4011Y	VGD20.4011Y	\$55590-G105-A100	VGD20.4011C
2"	100	BPZ.VGD20.503	VGD20.503	BPZ.VGD20.5011	VGD20.5011	BPZ.VGD20.5011Y	VGD20.5011Y	\$55590-G106-A100	VGD20.5011C
2"	100	---	---	BPZ.VGD20.5011A	VGD20.5011A	---	---	---	---

VGD40

DN	Flow rate at $\Delta p = 1 \text{ kPa}$ m^3/h air					VGD40.xxxL with inverted position of mounting plates (see Dimensions)		VGD41.xxx with AGA40.41 on both sides, refer to Dimensions	
		Article no.	Type	Article no.	Type	Article no.	Type	Type	Article no.
40	85	BPZ.VGD40.040	VGD40.040	---	---	BPZ.VGD40.040L *)	VGD40.040L *)	BPZ.VGD41.040	VGD41.040
50	100	BPZ.VGD40.050	VGD40.050	---	---	BPZ.VGD40.050L	VGD40.050L	BPZ.VGD41.050	VGD41.050
65	100	BPZ.VGD40.065	VGD40.065	BPZ.VGD40.065J	VGD40.065J	BPZ.VGD40.065L	VGD40.065L	BPZ.VGD41.065	VGD41.065
80	250	BPZ.VGD40.080	VGD40.080	BPZ.VGD40.080J	VGD40.080J	BPZ.VGD40.080L	VGD40.080L	BPZ.VGD41.080	VGD41.080
100	400	BPZ.VGD40.100	VGD40.100	---	---	BPZ.VGD40.100L	VGD40.100L	BPZ.VGD41.100	VGD41.100
125	630	BPZ.VGD40.125	VGD40.125	---	---	BPZ.VGD40.125L	VGD40.125L	BPZ.VGD41.125	VGD41.125
150	800	BPZ.VGD40.150	VGD40.150	---	---	BPZ.VGD40.150L	VGD40.150L	BPZ.VGD41.150	VGD41.150

*) On request

VRD4x

DN (mm)	Article no.	Type	Permissible operating pressure kPa	Air flow rate (m ³ /h) at $\Delta p = 1$ kPa	Number of test points Rp% *)	Number of pilot gas branches G% *)
40	BPZ-VRD40.040	VRD40.040	100	85	3	1
50	BPZ-VRD40.050	VRD40.050	100	100	3	1
65	BPZ-VRD40.065	VRD40.065	70	180	3	1
80	BPZ-VRD40.080	VRD40.080	70	250	3	1
100	BPZ-VRD40.100	VRD40.100	70	400	3	1
125	BPZ-VRD40.125	VRD40.125	70	630	3	1
150	BPZ-VRD40.150	VRD40.150	70	800	3	1

*) Both sides, inlet side, and outlet side

*) Inlet side

Ordering

When ordering, please quote the product type of the double gas valve.

The actuators, double gas valve, and flanges (VGD20 only) are supplied as single packs.

Example: VGD20

Double gas valve 2" with 2 flanges and 2 actuators

1 VGD20.503

2 x SKPx5 units

2 AGF10.50

Example: VGD4x / VRD4x

Double gas valve DN80 with 2 actuators

1 x VGD40.080 or VRD40.080

2 x SKP15.000E2s (actuator OPEN/CLOSED)

The lateral AGA40.4x units (pilot gas connection and pressure switch connection) are already included in the scope of delivery and ready fitted.

Accessories (to be ordered separately)



AGF10 flange

- Flange for VGD20 connection
- Order flanges individually
- Flanges can be combined with the VGD20 as desired

The following flange sizes and flange threads are available:

Flange		Nominal size (Rp)	Length in mm
Article no.	Type		
BPZ:AGF10.25	AGF10.25	1"	26
BPZ:AGF10.32	AGF10.32	1 ¼"	26
BPZ:AGF10.40	AGF10.40	1 ½"	26
BPZ:AGF10.50	AGF10.50	2"	30



Note

Scope of delivery: 1x O-ring
4x M8 x 27 screws
4x M8 nuts
4x lock washers \varnothing 8 mm



Pilot gas connecting plate for VGD4x / VRD4x

- Spare part (kit incl. grommet and gaskets)

AGA40.40
Article no.: BPZ:AGA40.40



Pressure switch connecting plate for VGD4x / VRD4x

- Spare part (kit incl. gaskets)

AGA40.41
Article no.: BPZ:AGA40.41



Adapter for SAX31 actuators

AGA60
Article no.: BPZ:AGA60

Consisting of 2 stem parts and one connecting flange.



Manually operated

AGA61
Article no. BPZ:AGA61



Gasket set for SKPx5

AGA66
Article no. BPZ:AGA66

- Between SKPx5 and VGD20 / VGD4x / VRD4x
- For improving the degree of protection from IP54 to IP65
- Recommended for installation in humid environments

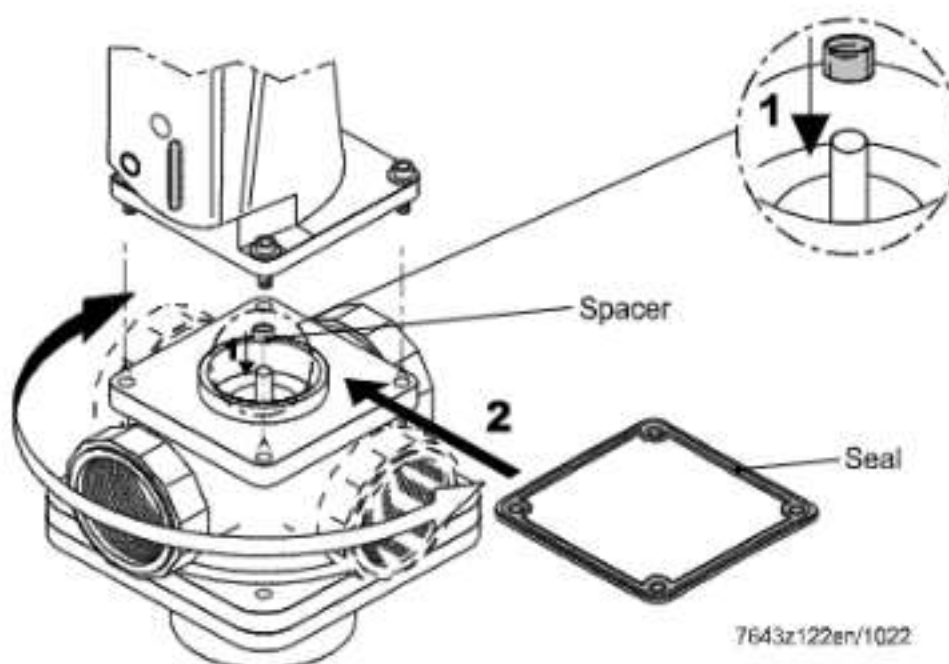

Please note!

The seal and the spacer must be mounted!

The seal must be mounted with its profile side facing the SKPx5. A suitable cable gland (SKPx5.xxxUx / NPSM liquid tight) or a suitable connector with a seal (SKPx5.xxxEx / AGA64 or AGA65) must also be used on the SKPx5.

Accessories (to be ordered separately) (Continued)



Service replacement kit for VGD20

AGA92

Article no. S55851-Z901-A100

- Required when replacing the VGD20 and retaining the old flanges AGA41 / AGA51
- Screw dimensions M8 x 35
- Consisting of:
8 screws, 8 washer, 8 nuts, 2 O-rings

QPL15 pressure switch for the VGD20 / VGD4x / VRD4x

- For monitoring the gas pressure or air pressure
- O-ring connection

Refer to Data Sheet N7221.

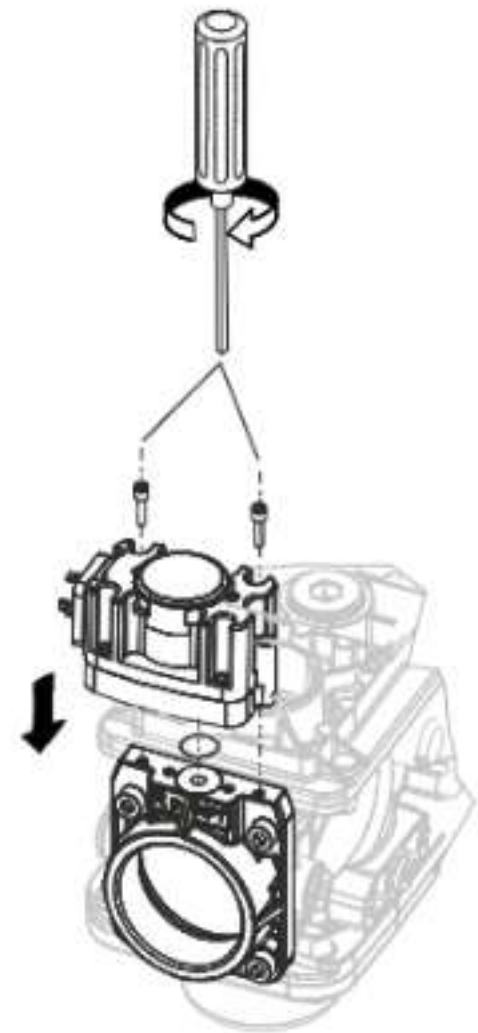
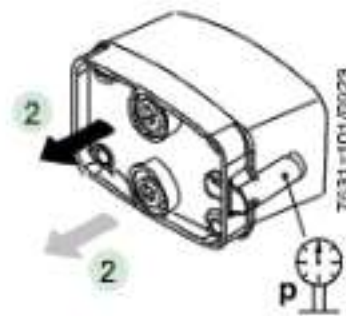

Accessories (to be ordered separately) (Continued)

QPL25 pressure switch for the VGD20 / VGD4x / VRD4x

- For monitoring the gas pressure or air pressure
- ¼" connection

Refer to Data Sheet N7221.

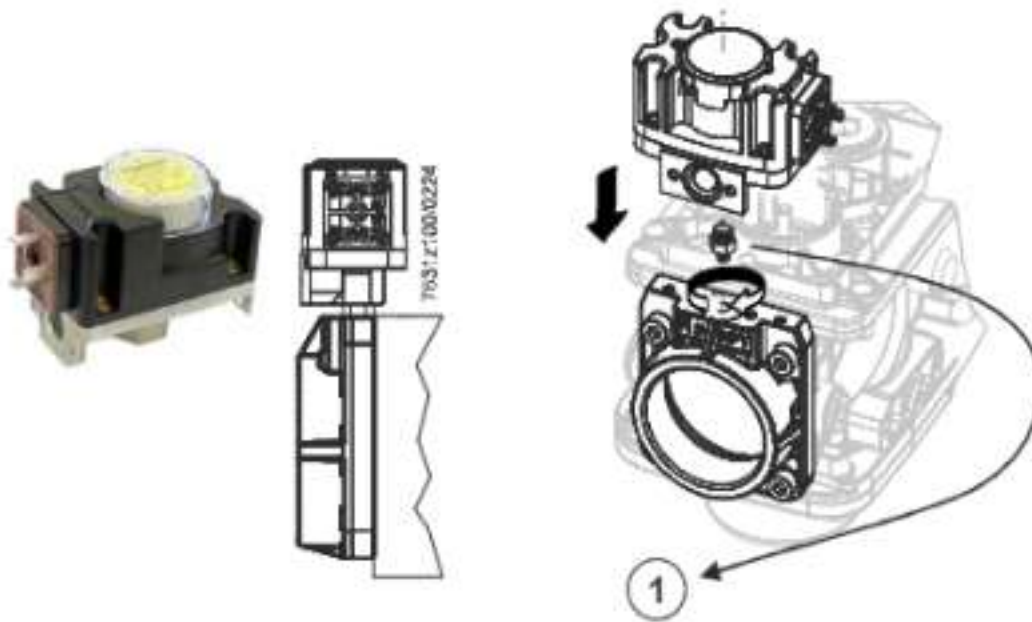

① Double nipple not included in scope of delivery of the QPL25



Double nipple (not included in scope of delivery of the QPLx5)

- Required for mounting the QPL25 gas pressure switch
- Double nipple (1/8" to 1/4") to be provided by the customer if necessary
- The QPL15 gas pressure switches can be mounted directly on the AGF10

Technical data

General valve data

Valve class in combination with SKPx5	A conforming to EN 161 (except with SAX31)
Group	2 (EN 161)
Perm. medium temperature	
• VGD20 / VGD4x	-15...60 °C
• VRD4x	0...60 °C
Weight	
• VGD20 / VGD4x	Approx. 3.2 kg
• VRD4x	See <i>Dimensions</i>
Connecting flanges for VGD4x / VRD4x	PN16 to ISO 7005-2
Required flow rate	See <i>Flow chart</i>
Permissible mounting position	Refer to chapter 'Mounting notes'

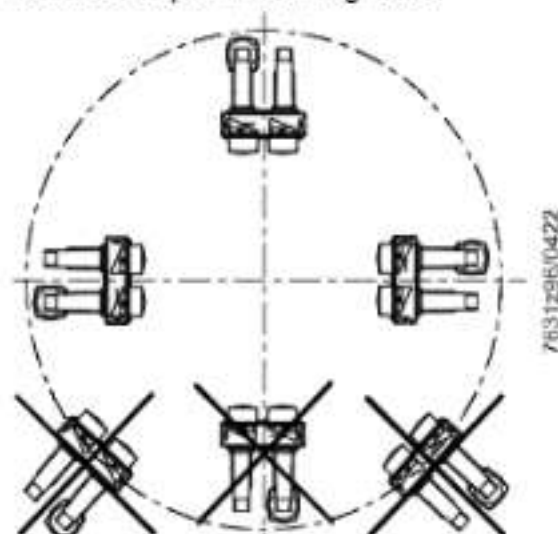

Operating pressure	See <i>Type summary</i>
Permissible gas pressure against the direction of flow	
• VGD20	15 kPa
• VGD4x / VRD4x	30 kPa
Types of gas	
• VGD20 / VGD4x	Suited for use with gases of gas families I...III and air
• VGD4x	Suitable for gases up to max. 0.1 Vol.-% H ₂ S, dry
• VRD4x	Suitable for biogases and recycling gases – up to maximum 1% by volume H ₂ S, dry – up to maximum 1% by volume NH ₃ , dry
	No non-ferrous metals (except in very small quantities found in the plastic components)
	For further instructions, refer to the <i>Application chapter</i> .
Strainer	Built in (mesh size 0.9 mm)
Materials	AlSi10Mg to DIN 1706

Technical data (cont'd)

Environmental conditions	Storage	EN 60721-3-1:1995 + A2:1997
	Climatic conditions	Class 1K3
	Mechanical conditions	Class 1M2
	Temperature range	-20...60 °C
	Humidity	<95% r.h.
	Transport	EN 60721-3-2:1995 + A2:1997
	Climatic conditions	Class 2K2
	Mechanical conditions	Class 2M2
	Temperature range	-15...60 °C
	Humidity	<95% r.h.
	Operation	EN 60721-3-3:1995 + A2:1997
	Climatic conditions	Class 3K5
Mechanical conditions	Class 3M2	
Temperature range	-10...60 °C	
Humidity	<95% r.h.	
Installation altitude	Max. 2,000 m above sea level	



Warning!

Condensation must not be allowed to form in the valve!

If this is not observed, there is a risk of safety functions being impaired.

Technical data (cont'd)

Permissible gas pressures/volumes	Type	Permissible maximum operating pressure (dynamic pressure) kPa	Volume between V1/V2 (liters)
	VGD20.2xx	150	0.75
	VGD20.3xx	150	0.75
	VGD20.4xx	150	0.75
	VGD20.5xx	150	0.8
	VGD40.040	100	0.8
	VGD40.050	100	0.8
	VGD40.065	70	1.3
	VGD40.065J	70	1.3
	VGD40.080	70	1.5
	VGD40.080J	70	1.5
	VGD40.100	70	3
	VGD40.125	70	5.2
	VGD40.150	70	8.7
	VGD41.040	100	0.8
	VGD41.050	100	0.8
	VGD41.065	70	1.3
	VGD41.080	70	1.5
	VGD41.100	70	3
	VGD41.125	70	5.2
	VGD41.150	70	8.7
	VRD40.040	100 (70)*	0.8
	VRD40.050	100 (70)*	0.8
	VRD40.065	70	1.3
	VRD40.080	70	1.5
	VRD40.100	70	3
	VRD40.125	70	5.2
	VRD40.150	70	8.7

*Australia only

VGD40 / VRD40

The VGD40 / VRD40s are designed to withstand gas pressures up to 150 kPa in burner standby mode. This pressure load is not present during normal operation, but only if the upstream pressure reducing device fails. At a pressure of 150 kPa, the VGD40 / VRD40s remains safely closed or will safely close. If the maximum permissible operating pressure is exceeded, a valve shutdown must be initiated. The functionality and the external tightness of the VGD40/VRD40 are not affected.

Note:

Owing to the internal design of the VGD40 / VRD40, increasing inlet pressure causes the valve to close (class "A" conforming to EN 161).

This means that safety shutoff or venting equipment that – in addition to the supply pressure regulator – are normally used for protecting the gas fitting on the burner (on the gas consumption equipment) are no longer required if the following 2 conditions are satisfied:

- If, in the event the supply pressure regulator upstream of the valve fails, 150 kPa at the inlet of the VGD40 / VRD40 are not exceeded and,
- in the event the permissible operating pressure of the VGD40 / VRD40 is exceeded (DN65...DN150: 70 kPa or DN40...DN50: 100 kPa), a shutoff device (e.g., gas pressure switch) causes the VGD40 / VRD40 to close.

Flow chart of VGD20 / VGD4x / VRD4x (only for fully open VGD20 / VGD4x / VRD4xs)

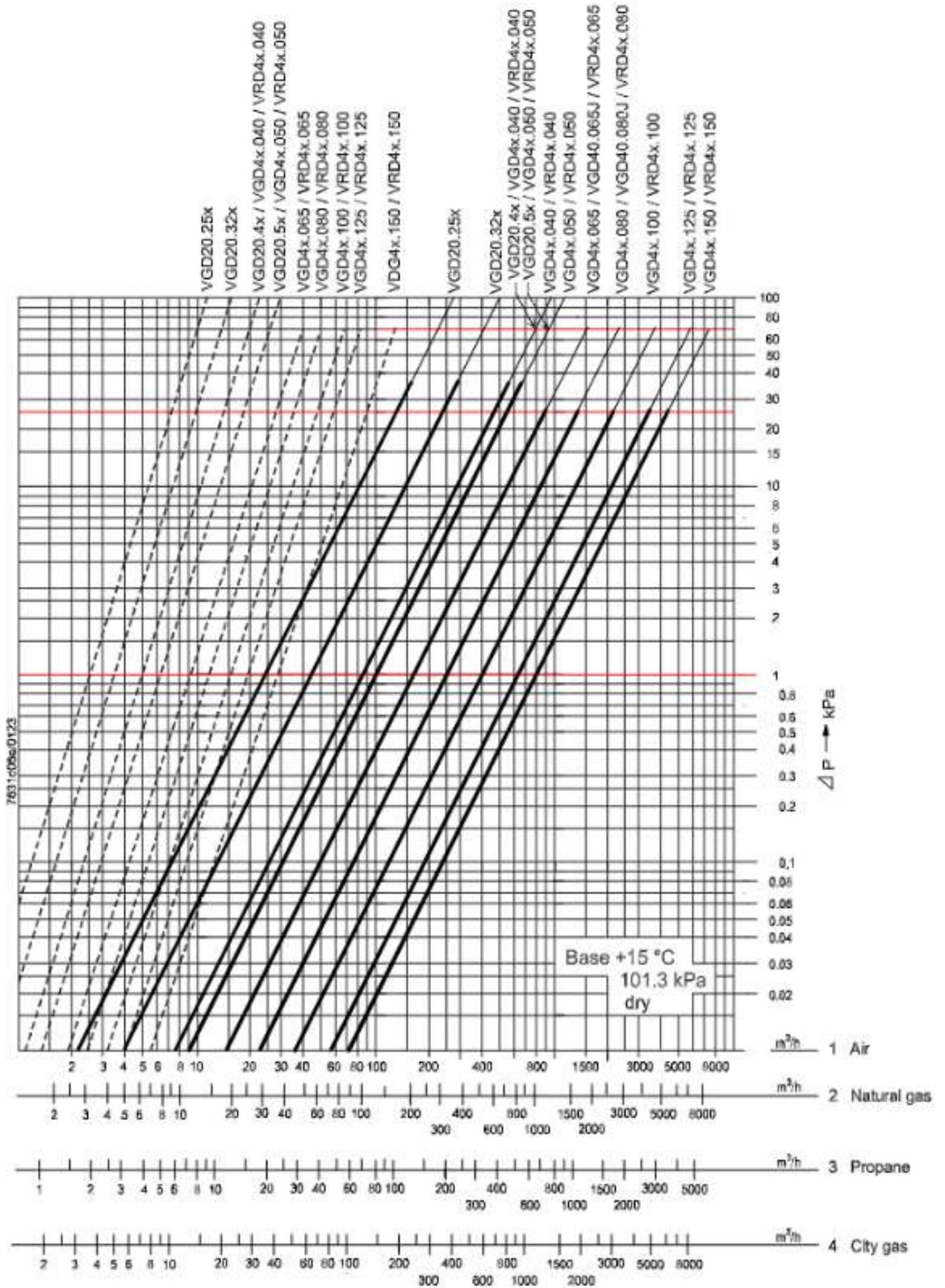

Flow chart of VGD20 / VGD4x / VRD4x (only for fully open VGD20 / VGD4x / VRD4xs) (cont'd)

Determination of pressure drop for gases with a density ratio (dv) other than that of the chart scales above:

Required variables
 $\rho(\text{Gas})$ Gas density in kg/m^3
 $V(\text{Gas})$ Gas volume in m^3/h

Procedure

- Calculate of the gas density ratio [dv(gas)]:

$$dv(\text{Gas}) = \frac{\text{Density (gas) in kg/m}^3}{1.22 \text{ kg/m}^3 (= \text{air density})}$$

- Determine the air volume [V(air)] that produces the same pressure drop (Δp) as the gas volume [V(gas)]:

$$V(\text{air}) = \frac{V(\text{gas) in m}^3/\text{h}}{\sqrt{dv(\text{Gas})}}$$

- Determine the gas pressure drop (Δp) with the help of the flow chart, based on the calculated air volume [V(air)] on the chart scale.

Operation beyond the range confined by the bold characteristics can lead to flow noise!



Attention!

- For applications with a large modulation range, select the smallest possible nominal valve size, see SKPx5 data sheet N7643
- If the gas pressure exceeds the maximum permissible operating pressure, reduce it with a pressure regulator installed upstream of the valve
- The pressure drop (lines of maximum flow) is based on a fully open VGD20 / VGD4x / VRD4x

Conversion of the air volume to a corresponding gas volume (natural gas)

Basis of scale	Abscissa	Medium Volumetric flow (QG) in m^3/h	Density ratio (dv) to air	Conversion factor $f = \sqrt{\frac{1}{d}}$
	1	Air	1	1
	2	Natural gas	0.61	1.28
	3	Propane	1.562	0.8
	4	Town gas	0.46	1.47

Conversion to air (m^3/h) from other types of gases:

$$Q_L = \frac{Q_G}{f}$$

Q_L = amount of air m^3/h producing the same pressure drop as Q_G

Example: Recommended working range (only for fully open VGD4x / VRD4xs)

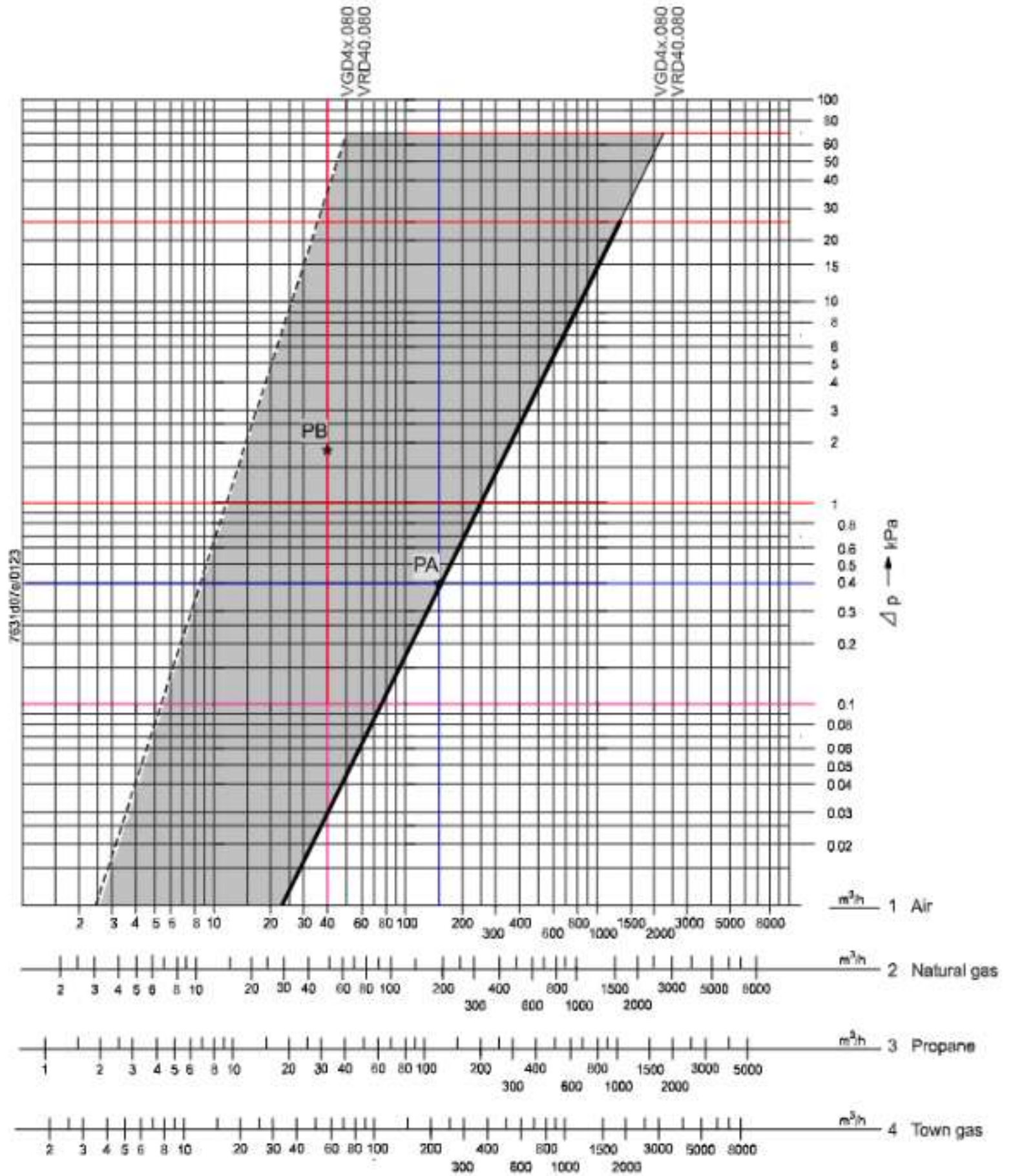

Legend

- Minimum flow characteristic (can vary, depending on the quality of the pressure test points)
- Maximum flow characteristic (for fully open VGD4x / VRD4xs)
- PA Working point
- PB Working point

For points PA / PB, refer to the *Sizing example* chapter.

Sizing example

Simplified example based on the above sizing chart: VGD20 / VGD4x / VRD4x with SKP75.

Prerequisite	Burner gas outlet toward the combustion chamber
Simplified example: Constant combustion chamber pressure	= 0 kPa
Required control ratio	RV = 4:1
Gas inlet pressure	2 kPa

1. **High-fire** → Point PA in the highlighted area
 Burner pressure at nominal load 1.6 kPa
 Volumetric flow at nominal load 200 m³/h natural gas, corresponding to 156 m³/h air
 - ΔpVx at nominal load 2.0 – 1.6 = 0.4 kPa
 Point PA must be on or to the left of the line representing the maximum flow characteristic

2. **Low-fire** → Point PB in the highlighted area

$$PG_{min} = \frac{PG_{max}}{RV^2} = \frac{1.6 \text{ kPa}}{16} = 0.1 \text{ kPa} \quad (\Delta p \text{ chart} = 2.0 - 0.1 = 1.9 \text{ kPa})$$

$$VG_{min} = \frac{VG_{max}}{RV} = \frac{200 \text{ m}^3/\text{h}}{4} = 50 \text{ m}^3/\text{h} \text{ corresponding to } h = 39 \text{ m}^3/\text{h} \text{ air}$$

– Selected valve size VGD40.080

Point PB must be on or to the right of the line representing the minimum flow characteristic.

Dimensions (not to scale)

Dimensions in mm



Note!

The VGD20s may only be mounted in conjunction with AGF10s.

VGD20.xx3 with AGF10

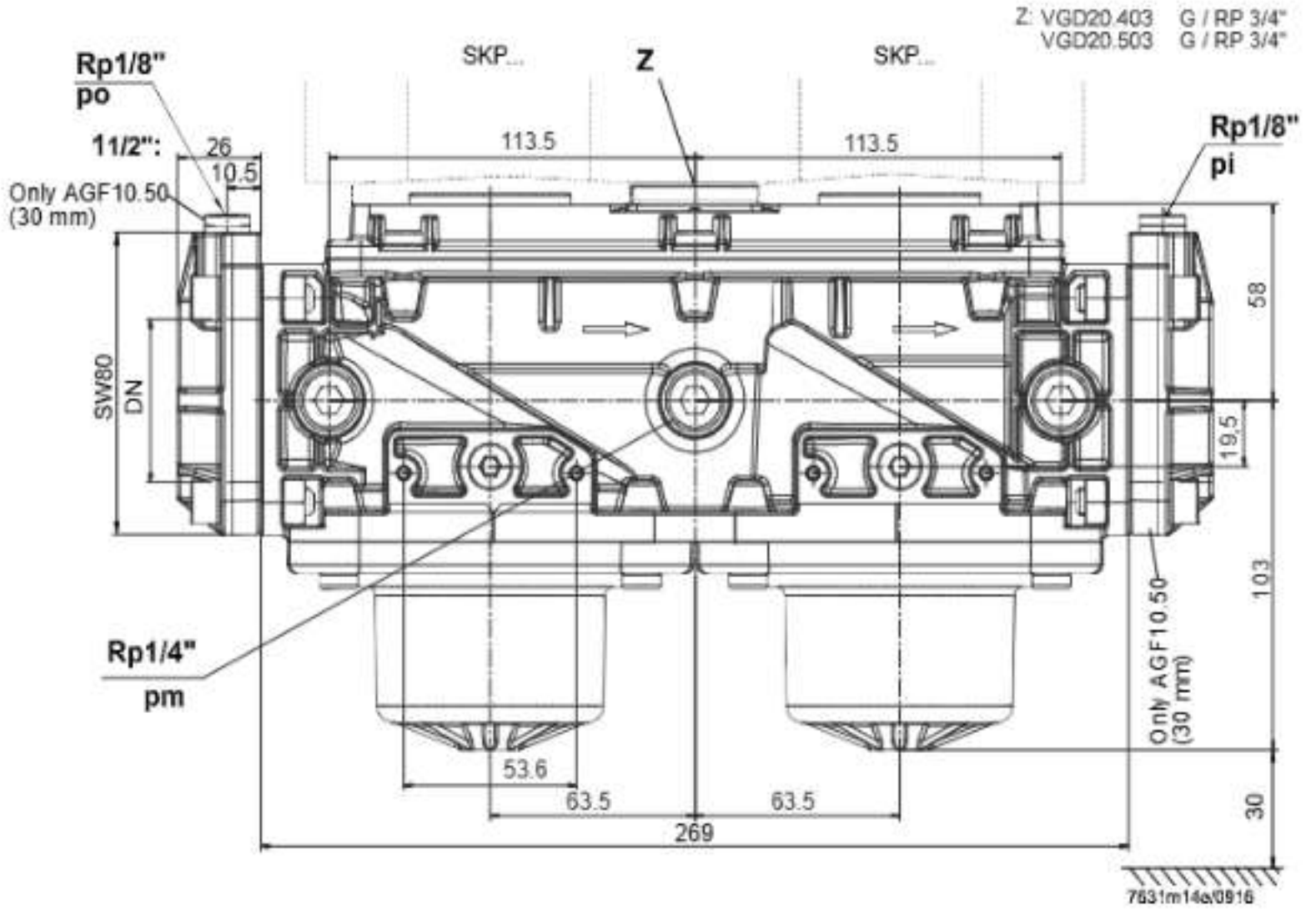

Dimensions (not to scale)

Dimensions in mm



Note!

The VGD20s may only be mounted in conjunction with AGF10s.

VGD20.xx11 with AGF10 (for dimensions, refer to VGD20.403/VGD20.503)

Z: VGD20.2511	G / RP 3/4"
VGD20.3211	G / RP 3/4"
VGD20.4011	G / RP 3/4"
VGD20.4011A	G / RP 1"
VGD20.4011C	G / RP 3/4"
VGD20.4011Y	G / RP 3/4"
VGD20.5011	G / RP 3/4"
VGD20.5011A	G / RP 1"
VGD20.5011C	G / RP 3/4"
VGD20.4011Y	G / RP 3/4"

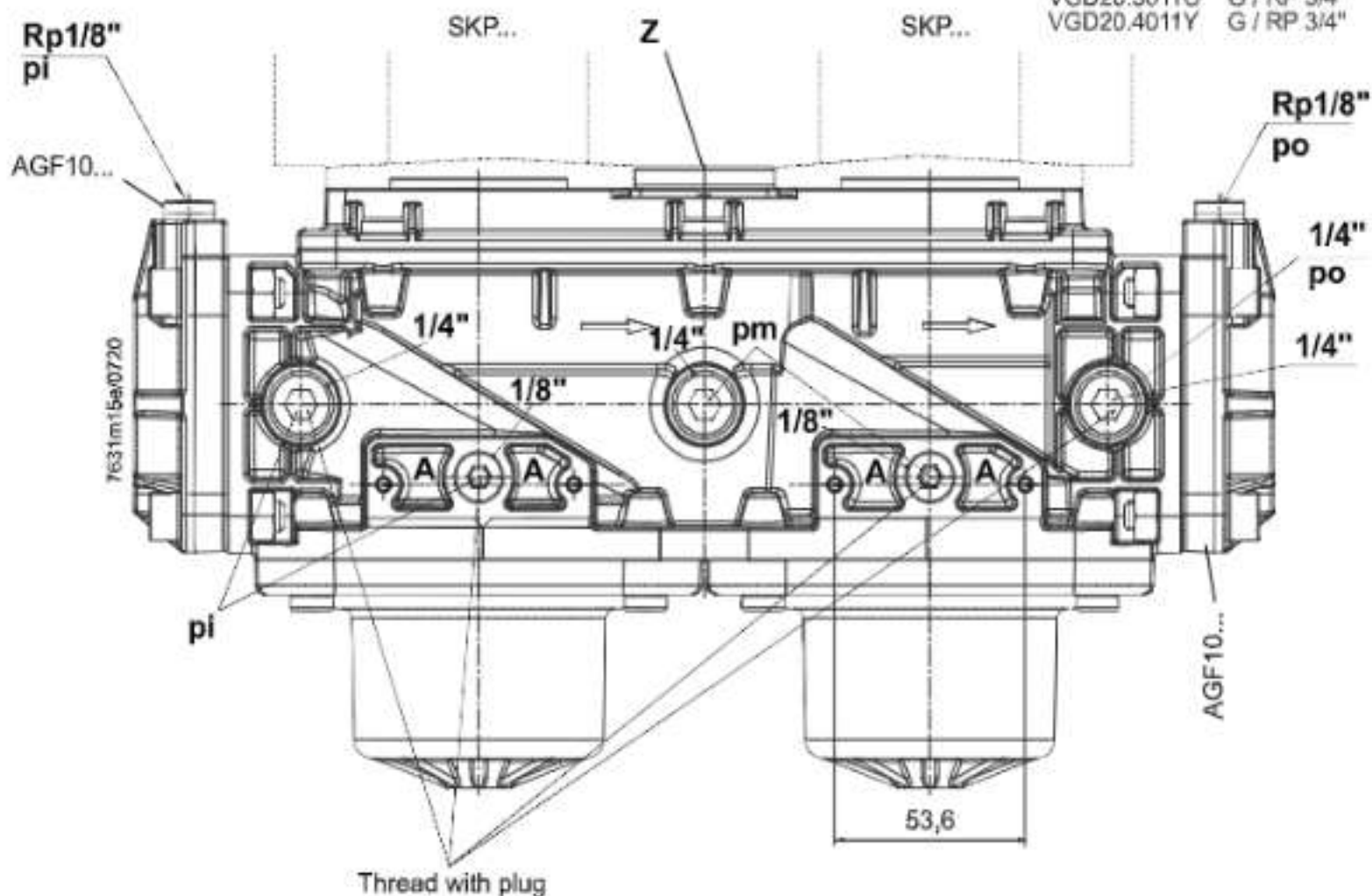

Note on 'A' label.

Holes for fastening the pressure switch (self-tapping cheese-head screw M4).

Dimensions in mm

VGD4x/VRD4x

VGD40 / VRD40

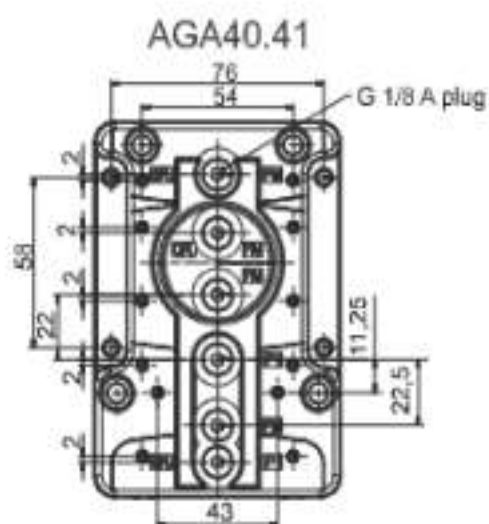
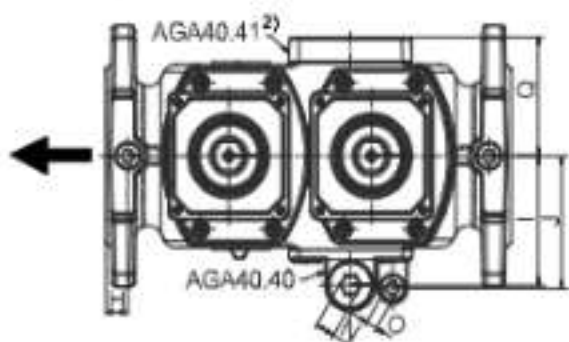
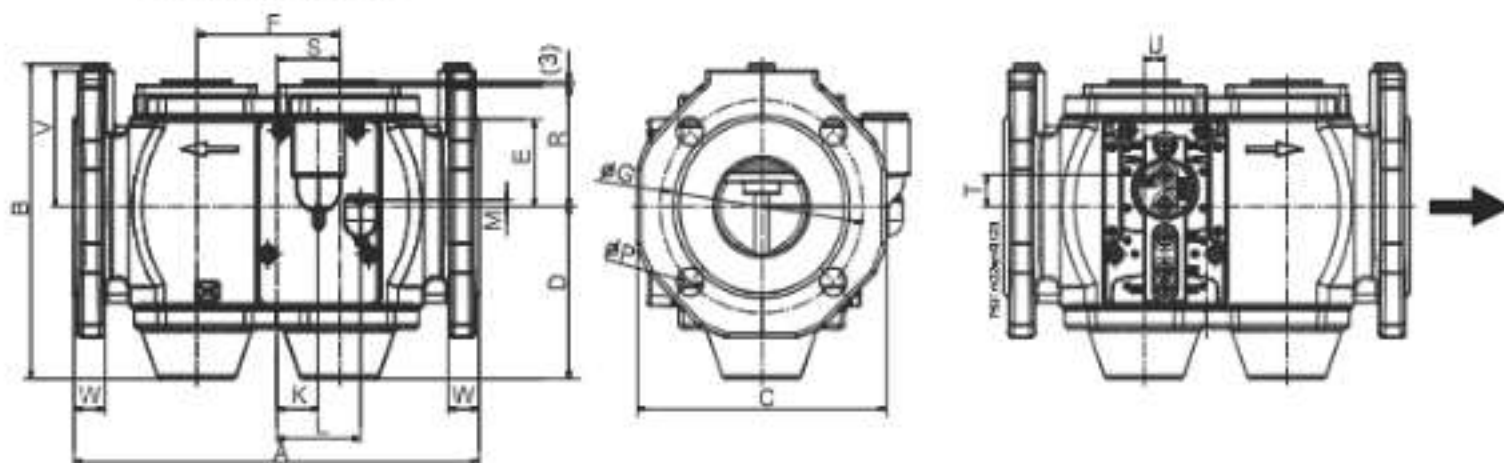

VGD40.xxxL

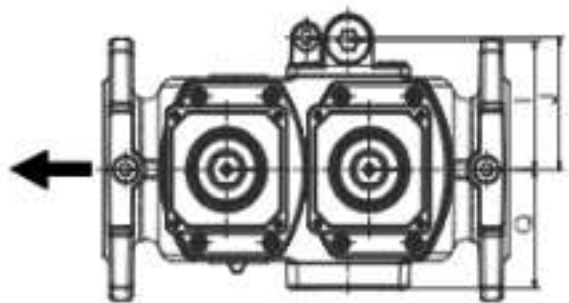

VGD41

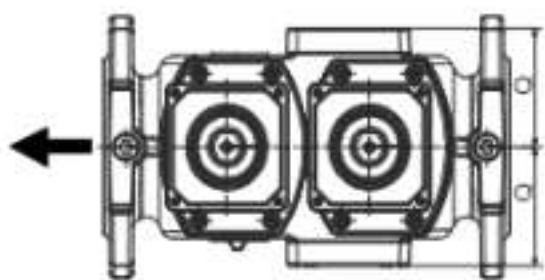

Dimensions (cont'd)

Table of dimensions

Type	DN ¹⁾	A	B	C	D	E	F	G	H	I	J	K	L	M	N	O	P	Q
VGD4x.040x VRD40.040	40	240	195	168	115	58	88	110	16	77	79	20	50	2	12	6	19	70
VGD4x.050x VRD40.050	50	240	202	175	115	58	88	125	16	77	79	20	50	2	12	6	19	70
VGD4x.065x VRD40.065	65	290	214	195	118	60	102	145	16	88	90	30	60	4	12	6	19	81
VGD40.065J	65	290	215	195	118	60	102	140	16	88	90	30	60	4	12	6	19	81
VGD4x.080x VRD40.080	80	310	236	204	132	54	107	160	16	90	92	30	60	3	12	6	19	88
VGD40.080J	80	310	238	204	132	54	107	150	16	90	92	30	60	3	12	6	19	88
VGD4x.100x VRD40.100	100	350	259	228	145	43	131	180	16	106	108	41	71	13	12	6	19	99
VGD4x.125x VRD40.125	125	400	305	256	175	31	150	210	16	120	122	41	71	25	12	6	19	113
VGD4x.150x VRD40.150	150	480	335	294	188	20	168	240	16	140	143	39	69	36	12	6	23	134

Type	R	S	T	U	V	W	kg
VGD4x.040x VRD40.040	4	44	20	20	75	20	7.0 6.9
VGD4x.050x VRD40.050	4	44	20	20	82.5	20	7.2 7.1
VGD4x.065x VRD40.065	4	45	22	30	92	22	8.4 8.1
VGD40.065J	8	45	22	30	95	22	8.4
VGD4x.080x VRD40.080	8	48	16	30	100	24	9.6 9.4
VGD40.080J	8	48	16	30	102	24	9.6
VGD4x.100x VRD40.100	8	59.5	5	41	110	24	12.9 13.1
VGD4x.125x VRD40.125	8	69	7	41	125	26	18.2 18.7
VGD4x.150x VRD40.150	8	78	18	39	142	26	24.1 24.4

Legend

- 1) Flanges to ISO 7005-2
 - 2) VGD41 has an AGA40.41 on both sides and no AGA40.40
 - 3) With the VGD40.xxxL, the mounting position of the two AGA40.4x units is reversed
- DN Nominal size, dimensions of connection
R Number of boreholes in the flange

Dimensions in mm

AGF10 (Europe)

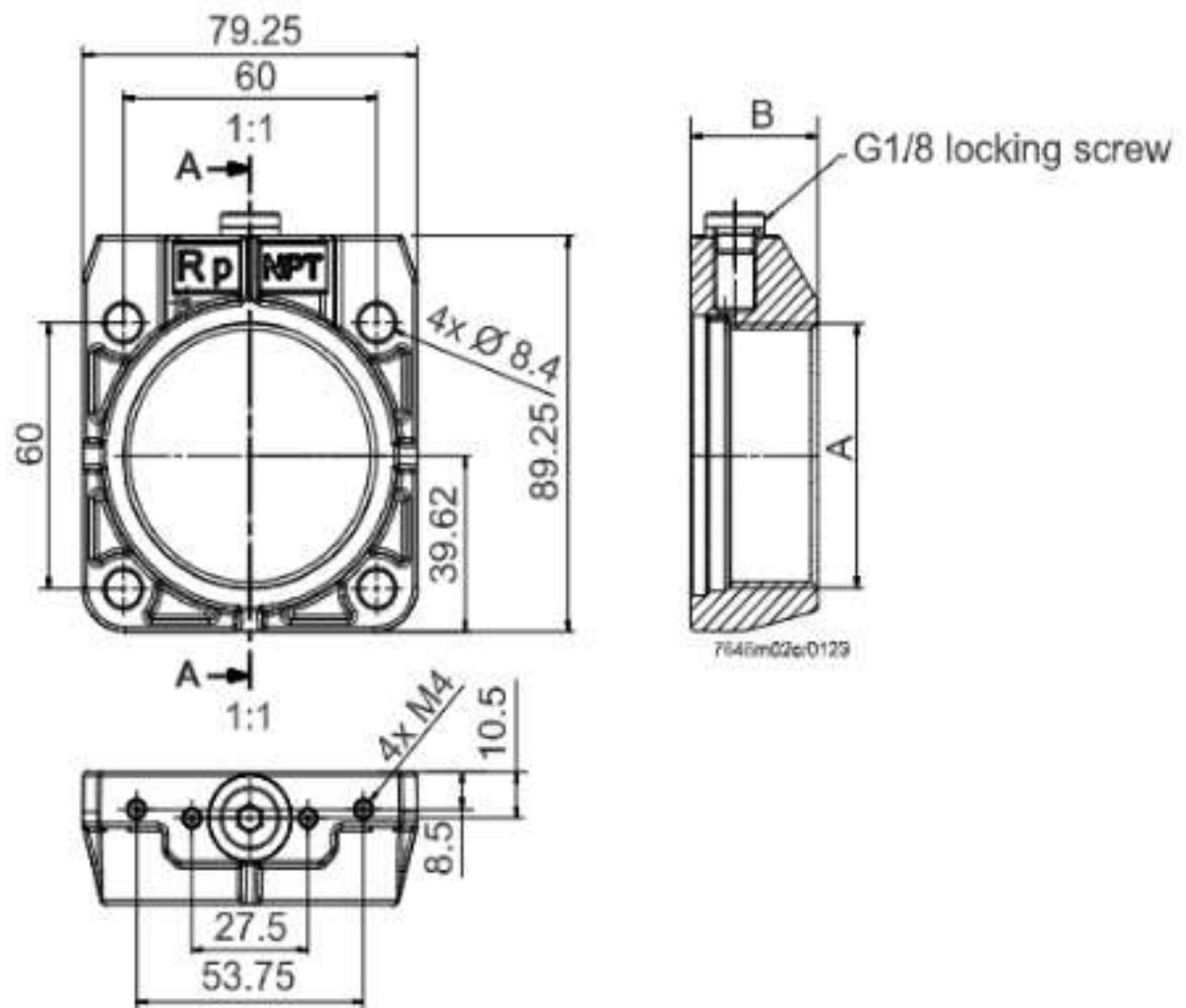

Type	A	B [mm]	Total weight
AGF10.25	Rp1"	26	269 g
AGF10.32	Rp1 1/4"	26	264 g
AGF10.40	Rp1 1/2"	26	261 g
AGF10.50	Rp2"	30	271 g