



Heating Element

AGA63...

Heating element for use with SKP... and SKL... actuators.
The AGA63... extends the field of use of actuators and makes them more reliable at low or significantly varying ambient temperatures.

The AGA63... and this Data Sheet are intended for use by OEMs which integrate the SKP... / SKL... actuators with the heating element in their products!

Use

The heating element is designed for use with SKP... or SKL... actuators on gas-fired combustion plant.

Warning notes



To avoid injury to persons, damage to property or the environment, the following warning notes should be observed!

Do not to open, interfere with or modify the heating element!

- All activities (mounting, installation and service work, etc.) must be performed by qualified staff
- Before making any wiring changes in the connection area, completely isolate the heating element from the mains supply (all-polar disconnection)
- Ensure protection against electric shock hazard by providing adequate protection for the connection terminals
- Each time work has been carried out (mounting, installation, service work, etc.), check to ensure that wiring is in an orderly state
- Fall or shock can adversely affect the safety functions. Such heating elements must not be put into operation, even if they do not exhibit any damage

Mounting notes

Ensure that the relevant national regulations for electrical installations are complied with.

AGA63.5A27
for fitting to SKPx5...
or SKL25...



The AGA63.5A27 is to be secured to the SKPx5... or SKL25... by means of 2 tension springs. First, hook the open eye of the spring in the aluminium base between the black covers of the SKPx5... or SKL25... Then, hook the closed eye in the recess of the AGA63.5A27.



To avoid the risk of injury due to slipping, use a pair of pliers when fitting the springs!

Installation notes

- Live and neutral or protective earth conductors must not be interchanged
- The power supply should be fused with a fuse type 6,3 A IEC 60127-2/V
- For electrical connections, refer to «Function»

Commissioning notes

- The AGA63... features heating control and adopts different housing temperatures, depending on the ambient temperature. The lower the ambient temperature, the higher the housing temperatures since the heat output increases

Standards and certificates



ISO 9001: 2000
Cert. 00739



ISO 14001: 1996
Cert. 38233



Conformity to EC directives

- Electromagnetic compatibility EMC (immunity)
- Directive for gas appliances
- Directive for pressure devices

89 / 336 / EEC
90 / 396 / EEC
97 / 23 / EC

Disposal notes



The heating element contains electrical and electronic components and must not be disposed of together with domestic waste.
Local and currently valid legislation must be observed.

Mechanical design

The heating element is an autonomous functional unit operating on AC 230 V.
It is supplied complete with a 3-core connecting cable of 1.3 m with ferrules.
The AGA63... contains a thermal cutout (nonexchangeable) to ensure protection against overtemperatures.

Type summary and ordering

Heating element

AGA63.5A27

The heating element is suited for use with the following types of actuators:

- SKP15...
- SKP25...
- SKL25...
- SKP55...
- SKP75...

The heating element is supplied complete with 2 tension springs for fixing.

Technical data

General element data	Mains voltage	AC 220 V –15 %...AC 240 V +10 %
	Mains frequency	50...60 Hz ±10 %
	Power consumption	max. 150 VA min. 5 VA
	On time	100 %
	Weight	approx. 490 g
	Connecting cable	3 x 1 mm ² , flexible, «L, N, PE»
	Degree of protection	IP 40
	Environmental conditions	Storage
Climatic conditions		class 1K3
Mechanical conditions		class 1M2
Temperature range		-10...+60 °C
Humidity		< 95 % r.h.
Transport		DIN EN 60 721-3-2
Climatic conditions		class 2K2
Mechanical conditions		class 2M2
Temperature range		-40...+60 °C
Humidity		< 95 % r.h.
Operation		DIN EN 60 721-3-3
Climatic conditions		class 3K3
Mechanical conditions	class 3M3	
Temperature range	-20...+60 °C	
Humidity	< 95 % r.h.	



Condensation, formation of ice and ingress of water are not permitted!



The temperature sensor inside the black housing acquires the temperature of the element at the location where it is in thermal contact with the actuator, thus ensuring that the temperature is maintained at a constant level of 40...45 °C.

This is true for an ambient temperature range of -15...+30 °C.

If the ambient temperature exceeds 30 °C, the heating element will be deactivated and the temperature of the actuator follows the ambient temperature with a differential of 15 K (e.g. «Tamb» 50 °C, «TSKP» 65 °C).

If the ambient temperature falls below -15 °C, the housing temperature of the actuator will be appropriately lower (e.g. «Tamb» -20 °C, «TSKP» 35 °C).

If ambient temperatures are lower, the rubber diaphragm of the SKP2..., SKL25..., SKP5... and SKP7... becomes stiffer, which may lead to unsatisfactory control performance.

If the ambient temperature falls below -20 °C, inadmissible gas pressure deviations can occur.

Electrical connections:

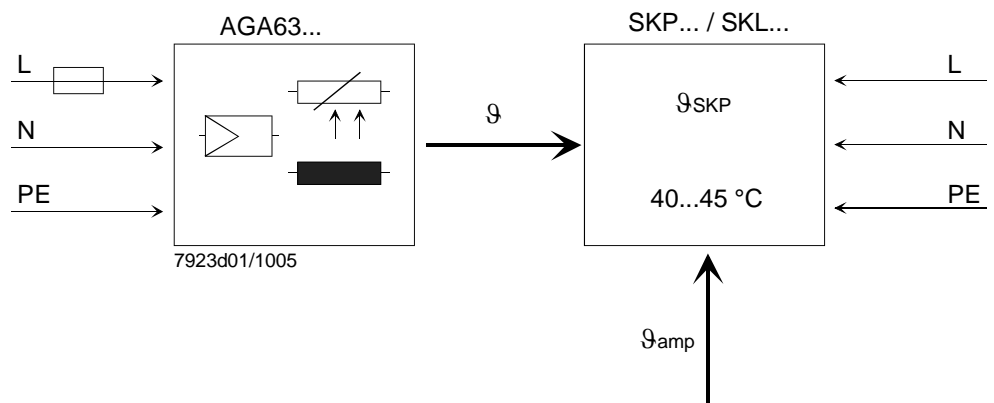

Dimensions in mm

AGA63.5A27

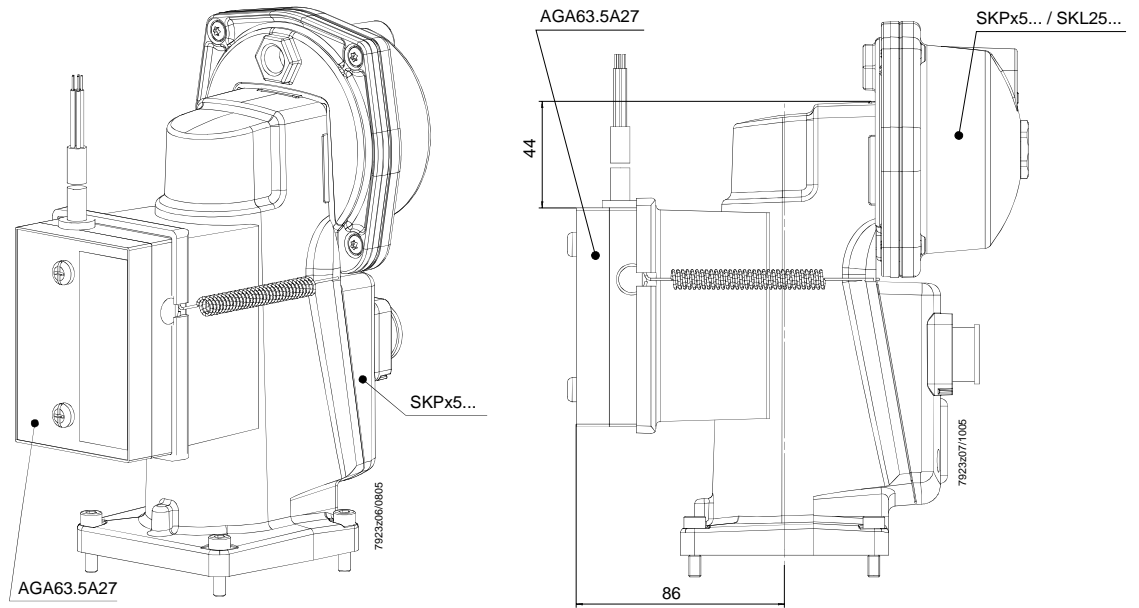

AGA63.5A27

