

Overflow valve with flange connection



Index

1	General Safety Notes	3
2	General Information	3
2.1	Operational limits	3
2.2	Operating principle.....	3
3	Installation.....	4
4	Initial Start-up and pressure adjustment.....	5
5	Application range and operation.....	5
6	Liquid fuels.....	5
7	Inspection and Maintenance.....	6
8	Dimensions.....	6
9	Flow characteristics $\Delta p - Q$	7

1 General Safety Notes

⚠ CAUTION	Indicates a potentially dangerous situation. If this is not avoided, small or light injury may result.
NOTICE	Indicates general information on a danger of property damage. Indicates general information on a danger of personal injury.

The notes for installation and maintenance are intended for a specialist!

The operator shall responsible for complying with general accident prevention, safety and operating provisions.

2 General Information

The hp–overflow valve is designed to control system pressure (only FDR 50-E) or to work as a max. pressure regulator. The valve has an adjustment screw for setting the system pressure. The pressure range can be changed to 4 alternative levels by exchanging the regulating spring (see chapter 4).

The Housing is designed in GGG40 cast iron.

The following information is engraved into the type plate of the overflow valve:

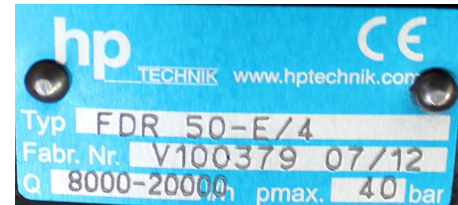

- Exact description of the overflow valve
- Serial number – NNNNN MM/YY
- Max. permitted operating pressure
- Flow rate

Model/Type designation: FDR 50–E/4

- FDR 50-E → Overflow valve with flow rate 8000 – 20000 l/h
- 4 → pressure stage

2.1 Operational limits

Flow	max. 20 000 l/h
Max. pressure	40 bar
Temperature	up to 150 °C
Max. viscosity	450 mm ² /s
Ambient temperature	-10 to +90 °C
Storage temperature	-10 to +60 °C

2.2 Operating principle

The overflow valve is pressure limiting, spring-loading piston valve. This valve limit and/or maintain the pressure in pressure line "P" to/at the valve set via the pressure spring, whereby any excess fluid is fed off into the return line "T".

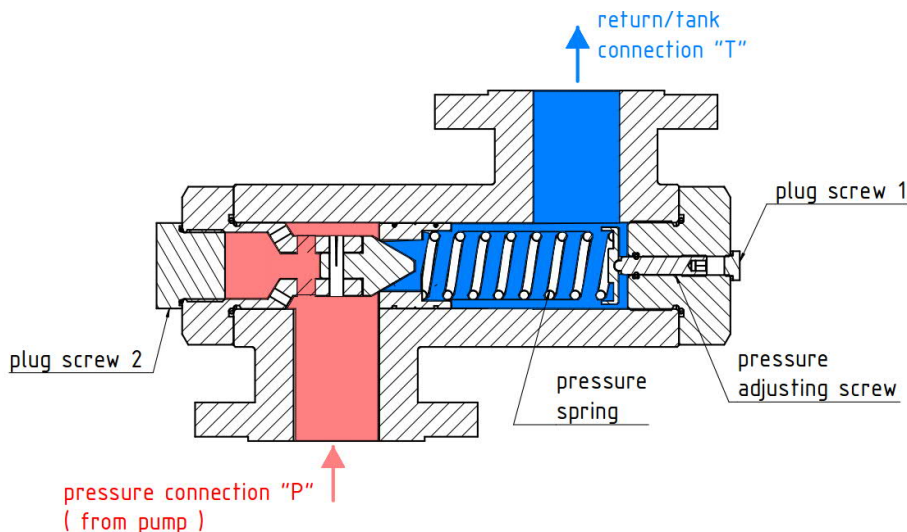

Fig.1 Operating principle

3 Installation

- Before connecting the lines, all plastic caps must be removed.
- All connections and lines must be installed free of tension and tight. We recommend only using sealing rings made of copper, aluminium or plastics. Never use hemp or similar materials. The pipes must be cleaned from any dirt and metal particles before the valve is connected.
- Should there be no manometer attached, please remove the plug screw 2 and fit one to the manometer connection G1/4" (Fig. 1) - applies to FDR 15 – FDR 32. For the valve FDR 50 is recommended, installation of the pressure gauge in the existing pressure pipe .

NOTICE

Never use water as purging liquid!
Danger of corrosion!

- The pressure line which fluid pressure is to be regulated by the overflow valve, shall be connected to the pressure connection "P".
- Please connect the return flow line, which has to lead back the controlled fluid from the regulating piston to the tank, to the return-flow / tank connection "T".
- The overflow valve can be connected at one pipe system to work as a max. pressure regulator (Fig.2) or at two pipe system to control the system pressure (Fig.3) – possible only with FDR50.

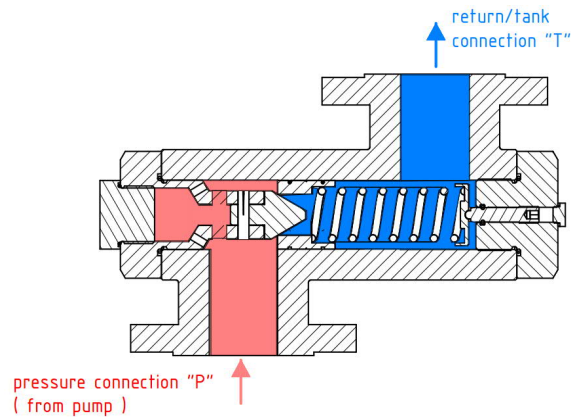

Fig.2 One pipe system

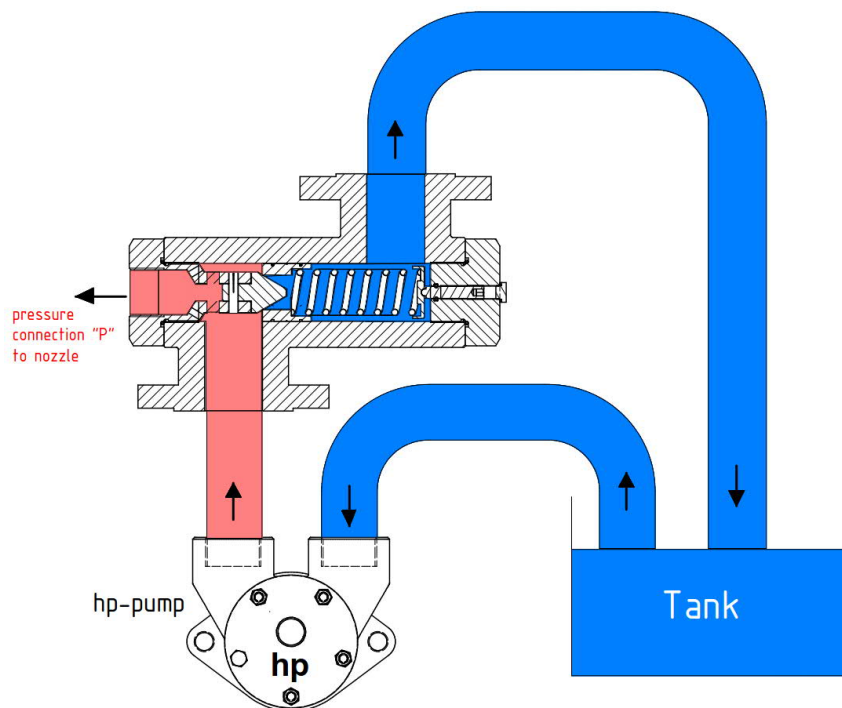

Fig.3 Two pipe system

Attention! The control of the system pressure at two pipe system is possible only with overflow valve FDR50.

4 Initial Start-up and pressure adjustment

- hp-overflow valves have been factory-set to the lowest possible pressure level of the respective pressure stage. In order to set the desired operating pressure, first remove the plug screw 1 (see Fig.1) to reveal the adjusting screw beneath.
- Now switch on the unit's pump and turn the adjusting screw to the right to adjust the operating pressure to the desired setting (turn the setting screw to the right – clockwise -> to increase the pressure, turn the setting screw to the left – counterclockwise -> to decrease the pressure. For a reading of the set value, Section 4.13 of DIN EN 12514-2, Issue 2000 calls for a manometer to be attached to the unit. Should there be no manometer attached, please remove the plug screw 2 (see Fig.1) and fit one to the manometer connection (only for FDR 15 – FDR 32). (For FDR 50 see chapter 3)
- After adjusting the pressure setting to the desired level, replace and retighten the plug screw 1. Assure that this screw is made tamper-proof as per Section 4.13 of DIN EN 12514-2, Issue 2000 by, for example, painting the plug screw with varnish so that any unauthorized tampering would be evident.

5 Application range and operation

When setting the desired operating pressure assure that a setting is chosen which is within the pressure range of the built-in pressure spring. The pressure spring code is the digit following the type designation (0-4, pressure stage)

Pressure range and pressure stage

pressure stage (PS)	Pressure range	
0	from 0,5 - 1,5 bar	not for FDR20, instead PS 1: 0,5 – 3,5 bar
1	from 1 - 4 bar	
2	from 2 - 9 bar	
3	from 6 - 25 bar	not PS 3 at FDR50
4	from 15 - 40 bar	PS 4 at FDR50: 6 - 40 bar

NOTICE

Setting a higher operating pressure (one that exceeds the design rated pressure range) will result in the pressure spring blocking.

6 Liquid fuels

Liquid fuels, mainly fuel oils derived from crude oil distillation, qualities according to DIN 51603 Part 1 – 5
 FAME – mix with fuel oil according to DIN 51603 Part 6 (FAME = Fatty Acid Methyl Ester)
 FAME 100% DIN EN 14214 respectively EN 14213
 Marine fuel ISO 8217 (HFO, MDF Kategorie ISO-F-DMX, DMA, DMB)
 Cold-pressed bio fuel according to DIN V 51605

Characteristics for different fuels (reference value)

Fuel	Density (at 20 °C)	Kin. viscosity (at 40°C)	Max. temperature at spraying viscosity *)
Unit	[kg/m ³]	[mm ² /s]	[°C]
Fuel oil (DIN 51603-1)	max. 856	max. 3,6	15
HFO (DIN 51603-3)		max. 1150	160
Re – raffinate (DIN 51603-4)		<45	90
Fuel oil (DIN 51603-6)	max. 860	max. 3,6	15
Marine Fuels (ISO 8217)	890 (15°C)	min: 1,4; max. 11	80
RME (DIN EN 14213)	856,6-896,6	3,5 – 5,0	28
Rape oil (DIN V 51605)	896,6-926,6	max. 36,0	85

*) temperature values are approximate

Chemical resistance of all parts for specified types of fuel. Non-standard fuels are excluded from the warranty.

7 Inspection and Maintenance

hp overflow valves are maintenance free.

Regular checks of the tightness and the reached pressures during operation are to be carried out weekly. Use a suitable pump filter/strainer to protect the pumps from dirt. (Please refer to the Operating Instructions for the pump in question.)

NOTICE

These mounting, maintenance and operating instructions are intended solely for the use of a trained specialist.

8 Dimensions

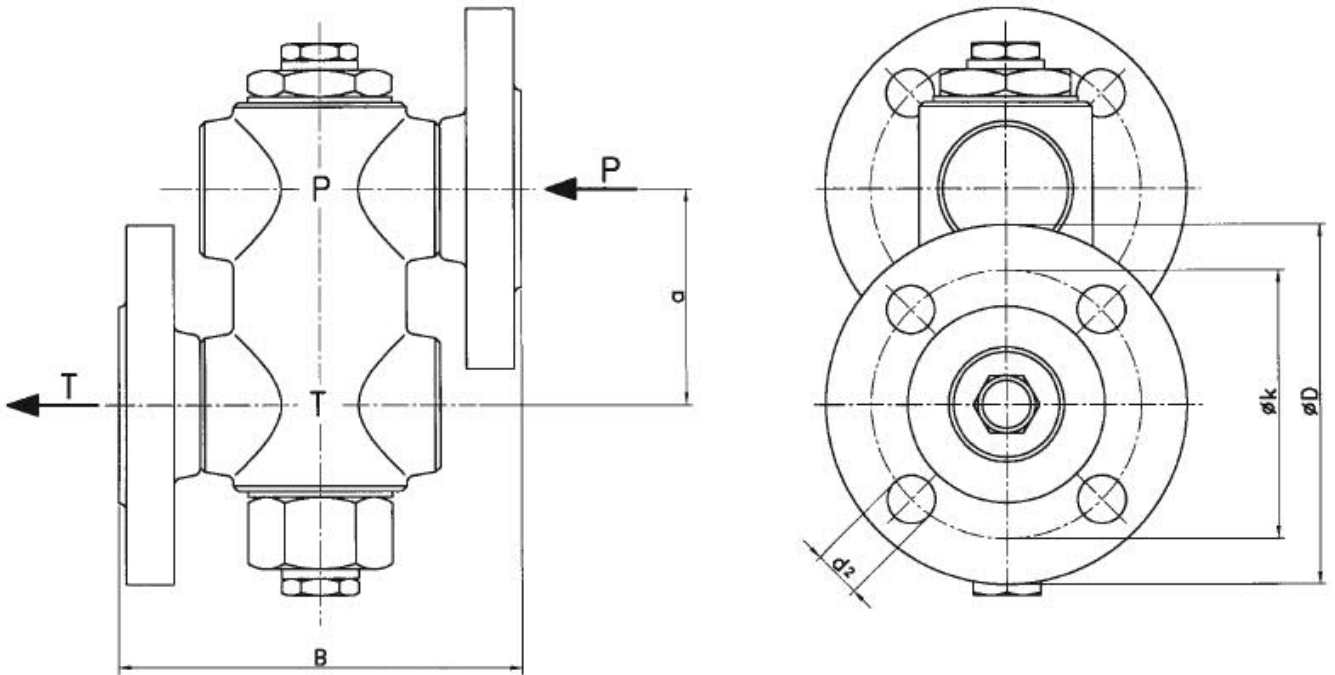
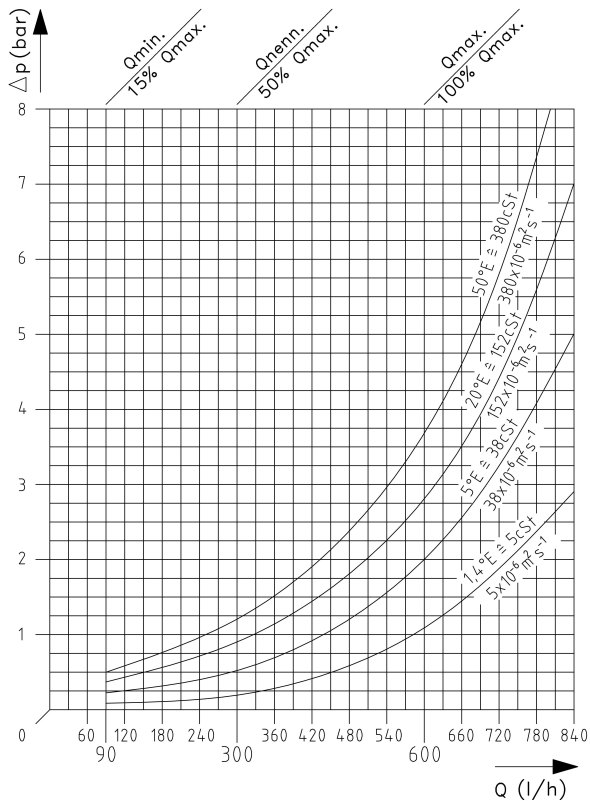

Fig.4 Dimensions

Type	a	b	DIN-Flange DIN 2635	Ø D	Ø k	Ø d ₂	Suitable counter flanges for PN 10 - 40 as DIN 2632-35
FDR 15	55	92	DN 15	95	65	14	
FDR 20	63	118	DN 20	105	75	14	
FDR 25	80	134	DN 25	115	85	14	
FDR 32	80	138	DN 32	140	100	18	
FDR 50	140	205	DN 50	165	125	18	

9 Flow characteristics $\Delta p - Q$

FDR 15 - E



FDR 20 - E

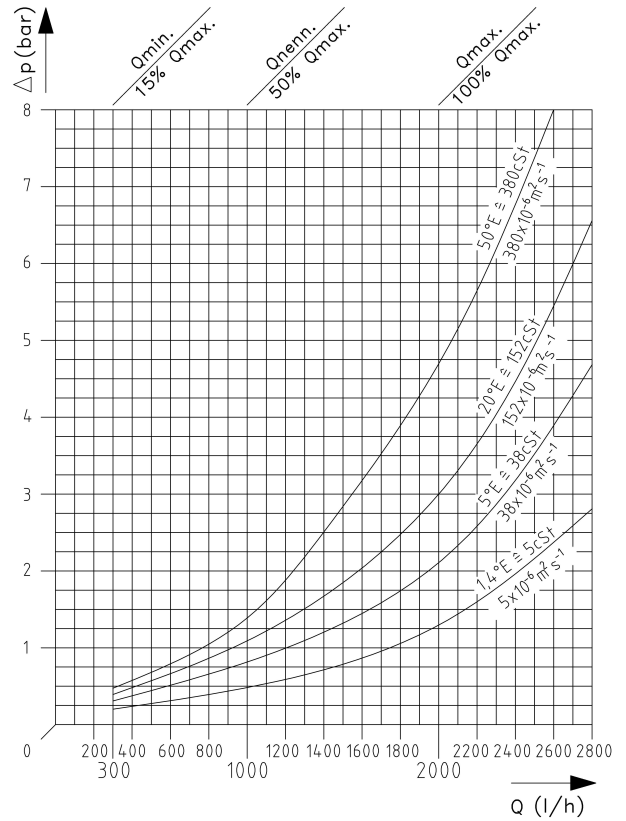

FDR 25 - E

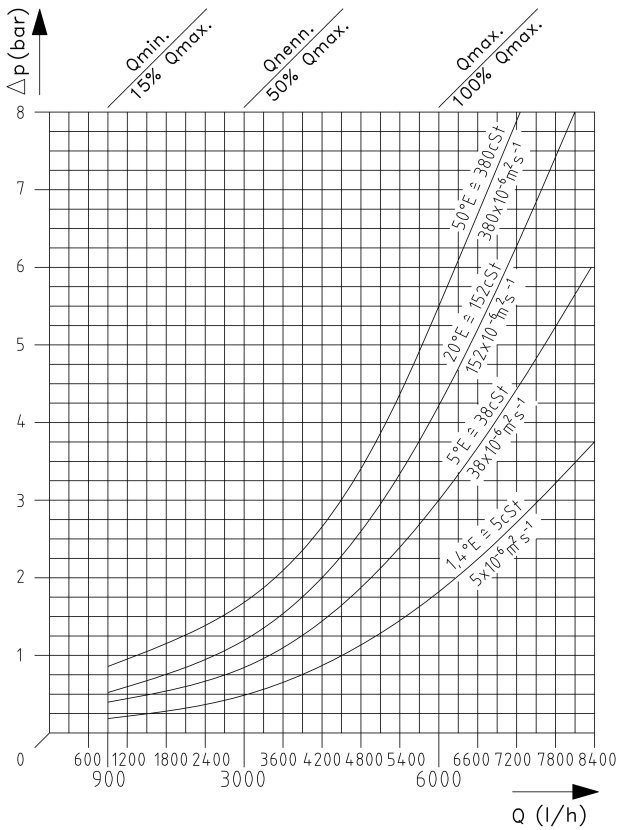

FDR 32 - E

